

Basement Development

Project Guide

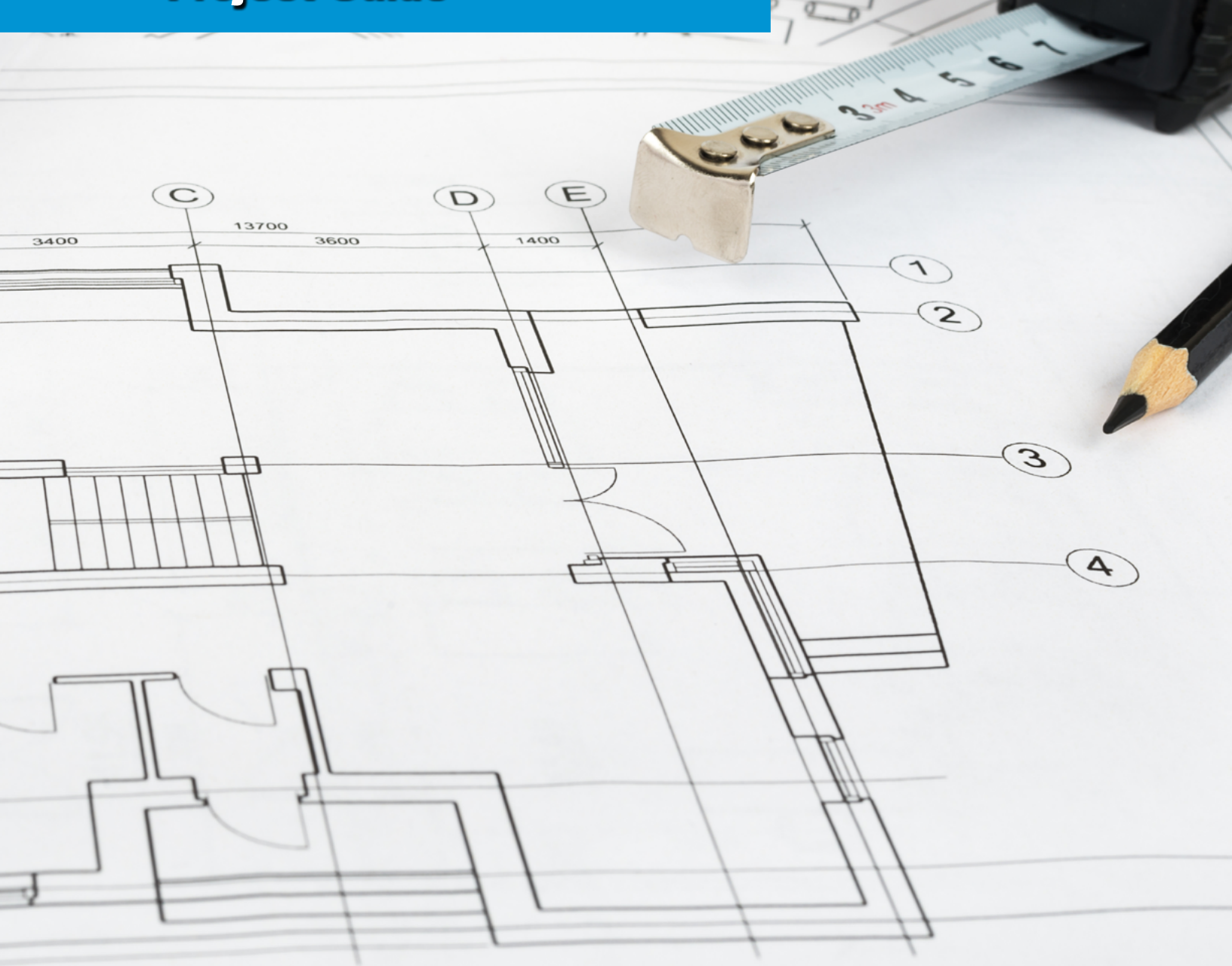

BASEMENT DEVELOPMENT

Applies to basement development construction in one-unit, two-unit and multi-family dwellings.

Note: if you are developing the basement as an additional dwelling unit, please apply for a secondary suite permit.

The following items must be included in your application package:

Submission Details Form

Floor plans (refer to sample floor plan on page 3)

- Dimensions of the entire basement
- Room use labelled (e.g. bedroom, mechanical, family room, etc.)
- Window location, size and unobstructed opening size
- Window well locations (dimension from edge of well to window, measured perpendicular to the exterior wall)

Other requirements that may need to be included in your application package:

Site plan (see sample on page 4)

- Required when adding or enlarging windows.

Elevation drawing (see sample on page 4)

- Required when adding or enlarging windows.

Spray foam insulation request form

- Required when using spray foam on your project

Engineered drawings (stamped drawings)

- Required for structural alterations outside Part 9 of National Building Code

Structural commitment letter for field review

- Required for a structural design completed by an engineer

The Energy Efficiency Compliance Form is required for alterations to the building envelope, windows or mechanical equipment for houses built after January 1st, 2019.



SUBMISSION DETAILS FORM

Complete the form below and submit with your application.

Address:

EXTERIOR WALLS

Framing, insulation, and vapour barrier completed under original building permit?

Yes No – please select one of the following options:

Standard wall construction

No additional drawings required.

Advanced/complex wall construction

Additional detail regarding the construction assemblies is required to be submitted.

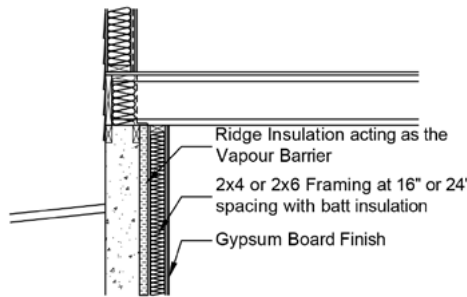
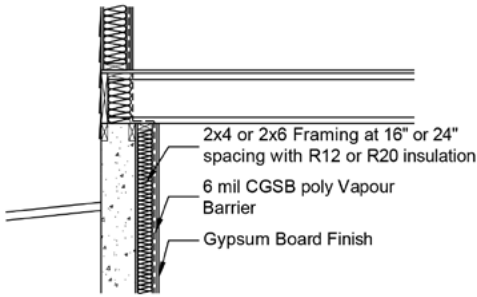

WINDOWS

Are you installing new windows, window well, or altering the size of an existing window?

Yes - please indicate location (bedroom, bathroom, etc) and size (w x h) below

No

Window 1	Location:	Size: W	mm x H	mm
Window 2	Location:	Size: W	mm x H	mm
Window 3	Location:	Size: W	mm x H	mm

** Bedroom windows must have a minimum opening of 0.35 m² (3.8 ft²) with with no dimension less than 380 mm (15 in).*

Window well

** A clear path of 760 mm (30 in) is required between the building or window swing for an exit from a bedroom. A window covered by a deck requires a 760 mm (30 in) clearance between grade and bottom of deck for exiting.*

SPRAY FOAM

Will you be using spray foam for your project?

Yes - please complete and submit a [Spray Foam Insulation Request form](#) with your application.

No

STRUCTURAL CHANGES

Structural changes include changes to beams, posts supporting beams, load-bearing walls, floors, wall opening enlargement or new openings in foundation wall.

Will there be any structural changes included with your basement development?

Yes - provide details on drawings (engineering may be required).

No

INFORMATION PACKAGE

To assist you in the construction of a basement development, we have created sample floor plans, site plans, elevation drawings to reference.

Sample Floor Plan

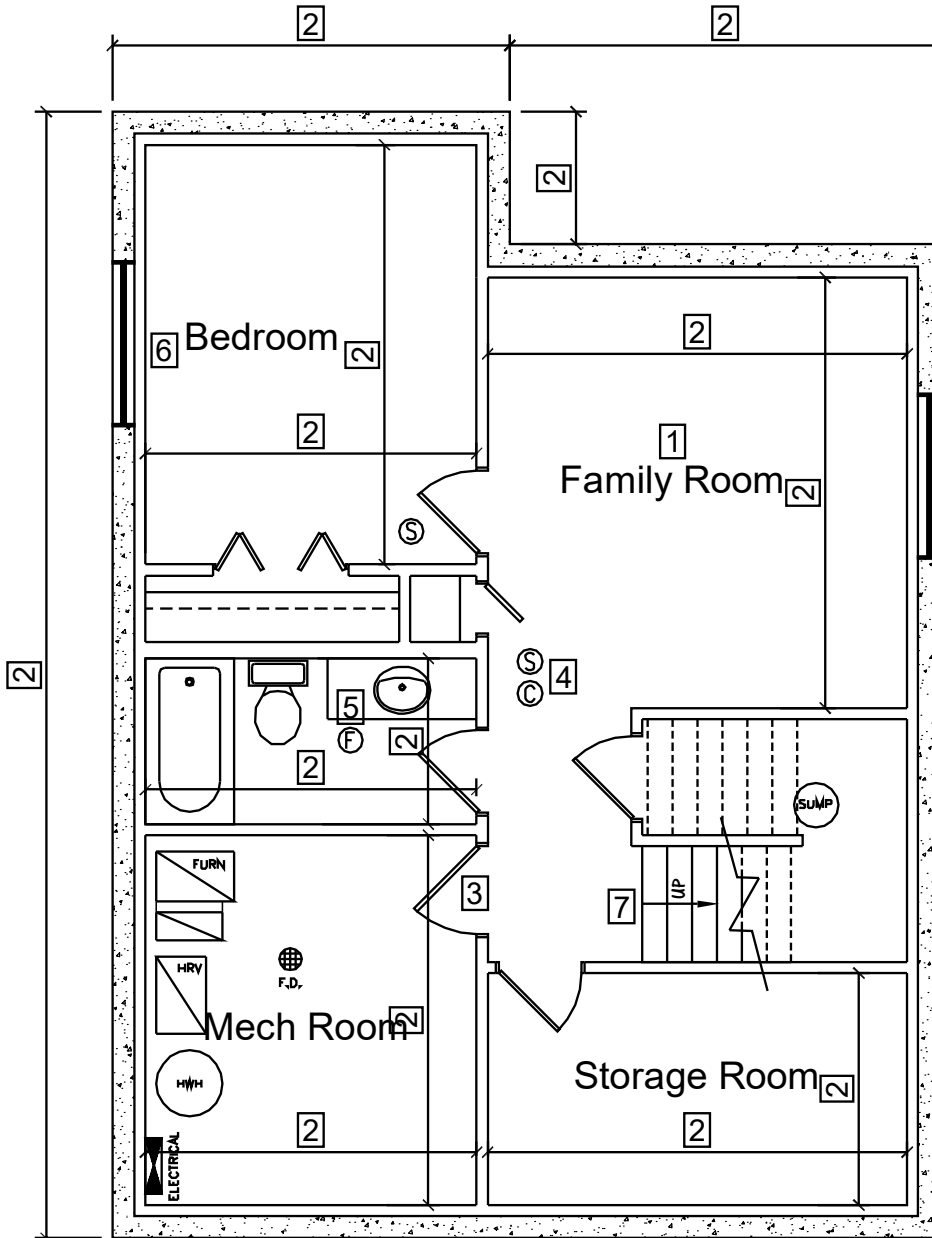

Details to be shown on plan:

- 1 Room labels
- 2 Room and basement perimeter dimensions
- 3 Door sizes
- 4 Smoke alarm & carbon monoxide detector locations
- 5 Bathroom exhaust fan location
- 6 Window type & opening size for bedrooms
- 7 Stair location

INFORMATION PACKAGE

New Window Sample Elevation Drawing and Site Plan

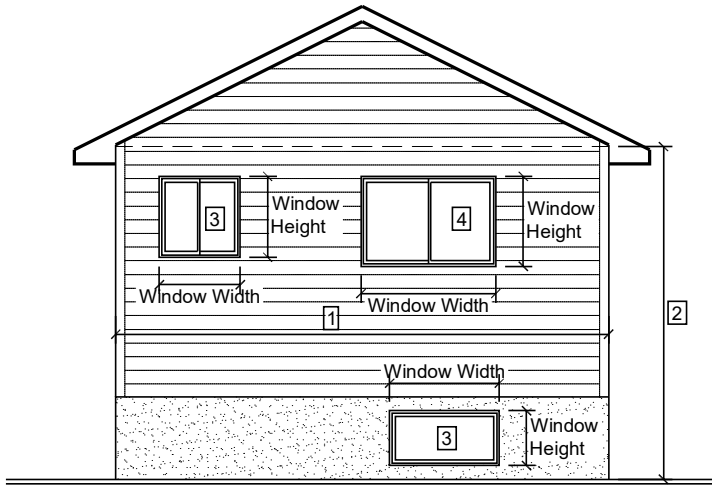

Details to be shown on Elevation Drawing:

- 1 Wall width
- 2 Wall height (measure from grade to ceiling)
- 3 Area of proposed windows (height & width)
- 4 Area of existing windows (height & windows)

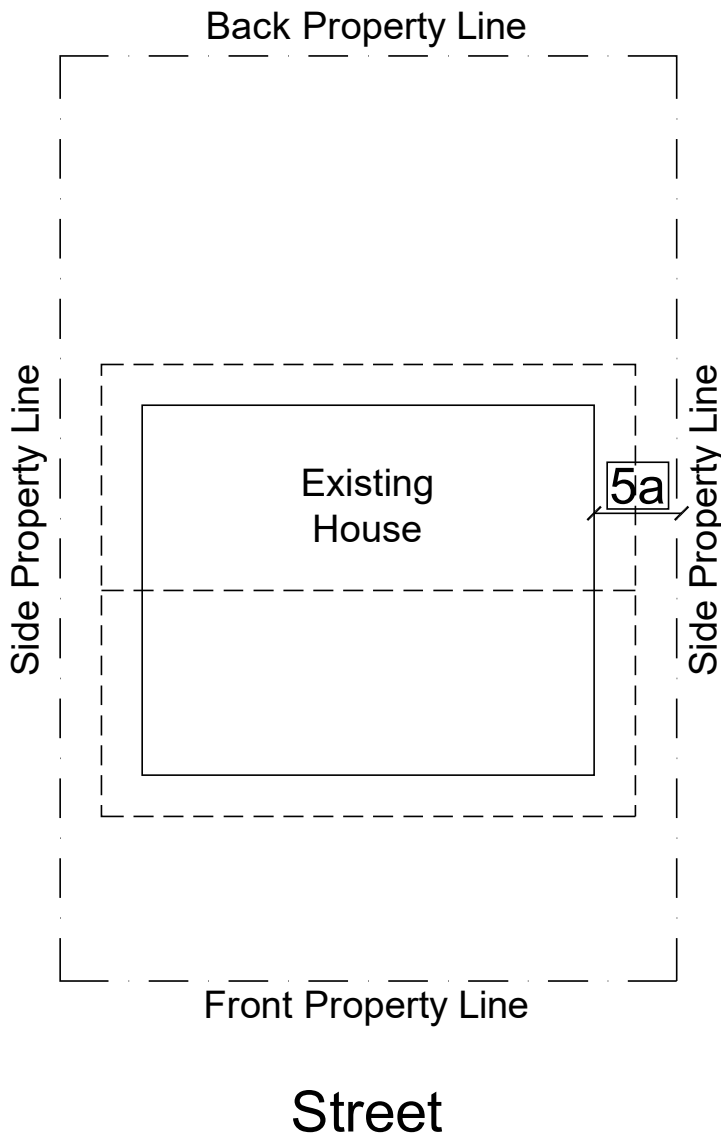

Details to be shown on Site Plan:

- 5 Site plan dimensions
- 5a Dimensions from wall face to property line

BUILDING CODE REQUIREMENTS

To assist you, we have provided National Building Code requirements that must be met and will be inspected. Please note that this is not an exhaustive list and exceptions may apply.

Alarms

Smoke alarms (Subsection 9.10.19)

Smoke alarms shall be interconnected, hard-wired and provided with battery backup. They shall be installed so that a smoke alarm is provided in the following locations:

- on each storey (including basements),
- in each sleeping room, and
- outside the sleeping room (between the sleeping room and remainder of the storey). If the sleeping room is served by a hallway, this smoke alarm must be in the hallway (Subsection 9.10.19).

Carbon monoxide detectors (CO) (Article 9.32.3.9)

- CO detectors shall be provided inside each bedroom, or within 5 m (16 ft 5 in) outside of each bedroom door, and
- In a room containing a solid-fuel-burning appliance (e.g., wood-burning fireplace) shall have a CO detector within the room.

Ceilings

Ceiling heights shall conform to Table 9.5.3.1. In general, the minimum height required is 2.1 m (6 ft 10 in).

Doors

Width and height (Article 9.5.5.1)

	Minimum width	Minimum height
Entrance to house	810 mm (32 in)	1980 mm (7 in)
Doors to stairs	810 mm (32 in)	1980 mm (78 in)
Utility room	810 mm (32 in)	1980 mm (78 in)
Walk-in closet	610 mm (24 in)	1980 mm (78 in)
Bathroom	610 mm (24 in) <i>(note: access to at least one bathtub/ shower and water closet must have doors that are 760mm wide)</i>	1980 mm (78 in)
Other rooms	760 mm (30 in)	1980 mm (78 in)

Hallways

Hallways shall be at least 860 mm (2 ft 10 in) wide (Article 9.5.4.1).

BUILDING CODE REQUIREMENTS

Framing

Foundation wall moisture protection of interior finishes (Article 9.13.2.5)

Interior dampproofing is required where wood framing or an interior finish is in contact with concrete basement wall.

- This moisture protection shall extend from the basement floor to the exterior ground level (on the cold side).

Insulation (Subsection 9.25.2)

Sufficient insulation shall be provided as part of the building envelope to ensure condensation does not occur during the winter and to ensure occupant comfort.

Foamed plastic insulation protection (Article 9.10.17.10)

Where foamed plastics are used in wall or ceiling assemblies (e.g., foam insulation boards, spray foam, etc.), they must be covered by:

- an interior finish from Subsections 9.29.4 to 9.29.9 (see wall/ceiling finishes for details), or
- a thermal barrier meeting Sentence 3.1.5.15.(2).

Air barrier (Subsection 9.25.3) and Vapour Barrier (Subsection 9.25.4)

Insulated assemblies shall have a vapour barrier. Vapour barriers shall be installed on the warm side of the assembly, shall have a permeance not greater than $60 \text{ ng}/(\text{Pa s m}^2)$ and shall comply with the appropriate standard for the material being used.

Wall stud height and spacing (Article 9.23.10.1)

- Wall stud height and spacing shall conform to Table 9.23.10.1.
- Commonly, non-load-bearing basement walls are framed with 2" x 4" studs at 400 mm (16 in) or 600 mm (24 in) on center.

Wood decay protection (Article 9.23.2.3)

If wood members are not pressure treated and are supported by concrete that is in contact with the ground, they shall have a 0.05 mm (2 mil) polyethylene film or Type S roll roofing in between the wood and the concrete support.

Finishing

Ceiling/Wall Finish (Section 9.29)

- Ceiling and Wall finishes can include gypsum board, plywood, plaster hardboard, insulating fireboard, particle board, OSB, waferboard and wall tile.
- Dropped or t-bar ceilings are also commonly used for ceilings.
- Waterproof finish is required to be provided to a height not less than
 - 1.8 m (6 ft) above floor in shower stalls
 - 1.2 m (3 ft 11 in) above the rims of bathtubs equipped with showers, and
 - 0.4 m (16 in) above the rims of bathtubs not equipped with showers.

BUILDING CODE REQUIREMENTS

Energy Efficiency Standards

Energy efficiency standards from Section 9.36 of the National Building Code of Canada are required if both of the following two items apply to your project.

- The building was constructed after January 1, 2019.
- The basement development includes alterations to the building envelope, windows or mechanical equipment.

Note: if the original construction was designed through a performance report, the building may already meet energy efficiency standards.

Windows

New windows or changes to window rough-openings

If a new window is being cut into the foundation, or if an existing window rough-opening in the foundation is being enlarged, engineering may be required. Details shall be provided on drawings.

Bedroom window(s) sized for egress (Article 9.9.10.1)

Each bedroom without an exterior door shall have a window that is:

- openable from the inside without the need for special tools or knowledge (e.g., windows or security bars that are unlocked by a key are not permitted),
- the window shall provide a clear opening of at least 0.35 m² (3.8 ft²) with with no dimension less than 380 mm (15 in), and
- the window shall remain in the opened position without the need for additional support (e.g., using a stick to hold a window open is not permitted).

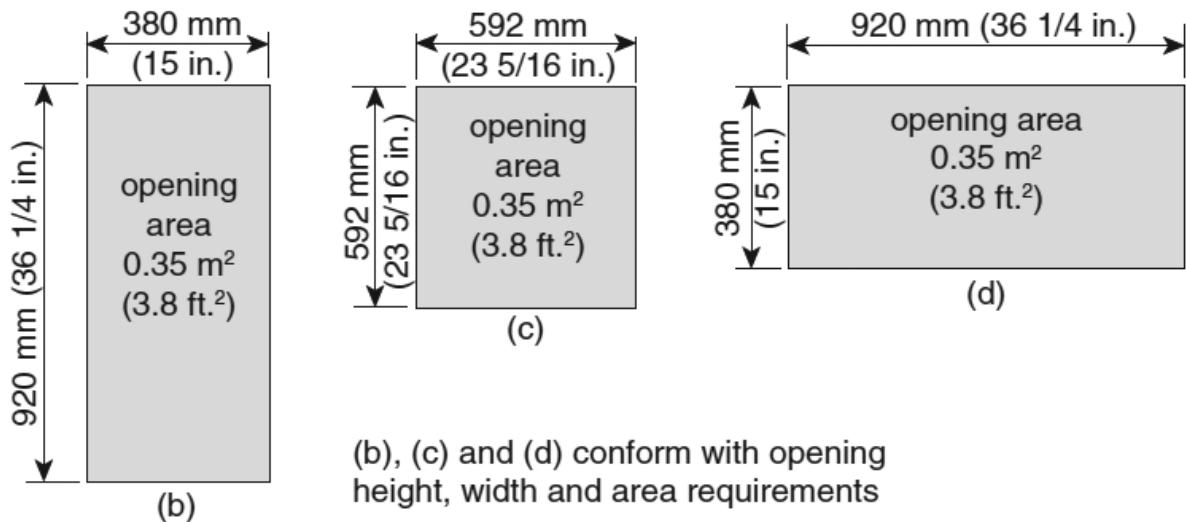

BUILDING CODE REQUIREMENTS

Bedroom window well sized for egress (Article 9.9.10.1) and drained (Article 9.14.6.3)

When an egress window opens into a window well, the window well must provide a clearance of at least 760 mm (30 in)

Window wells are to be drained to the footing level.

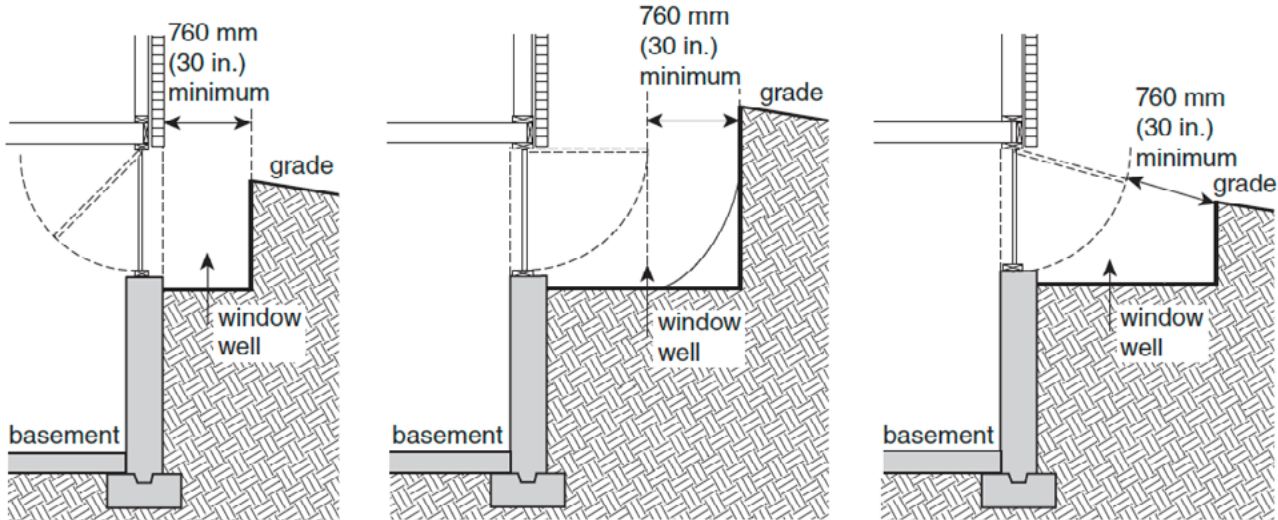

Ventilation

Exhaust in bathroom (Articles 9.32.3.7 to 9.32.3.8)

- A bathroom exhaust fan rated for a minimum of 25 L/s shall be provided in each bathroom or,
- an exhaust air intake from a principal ventilation fan (e.g. heat recovery ventilator (HRV)) should be provided in each bathroom (Sentence 9.32.3.7.(4)).

The owner shall ensure that introducing exhaust fans does not cause issues with depressurization and back drafting of fuel-fired equipment.

Warm air supply outlets (Article 9.33.6.11)

A warm air supply outlet shall be provided in each finished room that is adjacent to unheated space.

Return air inlets (Article 9.33.6.12)

At least one return air inlet shall be provided on each level. The return air inlet shall not be in a room that provides combustion air to a furnace.

BUILDING CODE REQUIREMENTS

Stairs

Required only if replacing existing stairs.

Width (Article 9.8.2.1) and headroom height (Article 9.8.2.2)

Stairs serving a single dwelling unit (house) shall be at least 860 mm (2 ft 10 in) wide. The headroom height shall be at least 1950 mm (6 ft 5 in).

Rise and run (Articles 9.8.4.1 - 9.8.4.8)

Treads and risers must have uniform rise and run in any flight, including top and bottom risers.

- Risers must be 125 mm (4 15/16 in) minimum to 200 mm (7 7/8 in) maximum.
- Runs must be 255 mm (10 1/16 in) minimum to 355 mm (13 15/16 in) maximum.

Landings (Subsection 9.8.6)

Landings are required at the top and bottom of each flight of stairs. In general, landings must be at least as wide and as long as the width of the stairs.

Handrails (Subsection 9.8.7)

Handrails are required on interior stairs with more than two risers (steps). Required handrails shall be 865 mm (2 ft 10 in) to 1070 mm (3 ft 6 in) high.

Guards (Subsection 9.8.8)

Minimum 900 mm (36 in) high measured vertically from the top of the guard to a line drawn through the leading edge of the stair treads. Openings in guards shall not exceed 100 mm (4 in).

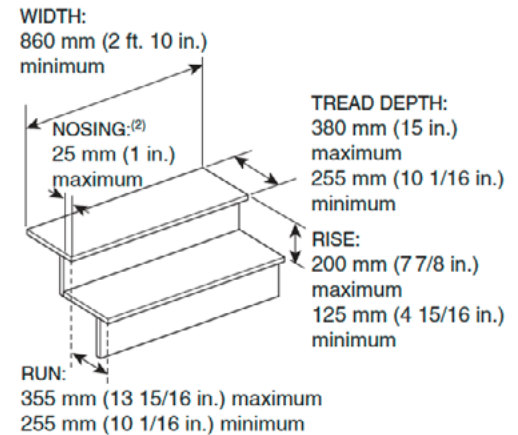

Private stairs

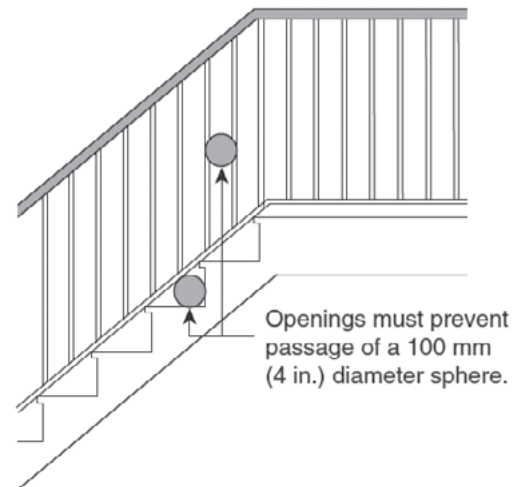

Required guards



222 3rd Avenue North
Saskatoon Saskatchewan S7K 0J5

P 306-975-2645 • **F** 306-975-7712
E buildingstandards@saskatoon.ca

saskatoon.ca/projectsguides

This project guide has no legal status and cannot be used as an official interpretation of the various codes and regulations currently in effect. Users are advised to contact Building Standards for assistance, as the City of Saskatoon accepts no responsibility for persons relying solely on this information.

REVISED FEBRUARY 2022