

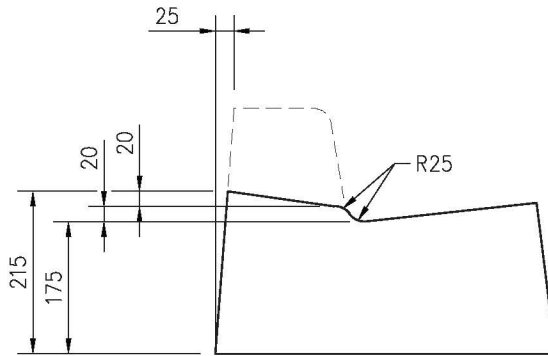

150mm SEPARATE CURB



VERTICAL CURB & GUTTER

NOTES:

1. CONCRETE STANDARD:  
32 MPa DURA-MIX CONCRETE  
5-8% AIR AS PER SPEC.
2. COMPACTION STANDARD:  
98% STANDARD PROCTOR AS PER SPEC.
3. BROOM FINISH TOP & FACE OF CURB AND GUTTER LONGITUDINALLY.  
BROOM OVER ALL CONTROL JOINTS.

PLAN DESCRIPTION/REVISION			DATE	BY	APPROVALS			
1	ORIGINAL STANDARD DRAWING		1999-FEB-01	RO	 SIGNATURE Todd Grabowski SIGNATURE Todd Grabowski			
2	ADDED MISSING DIMENSION AND UPDATED STANDARDS		2023-JAN-13	MLP				
 <b>City of Saskatoon</b> SEPARATE DROPPED CURB CROSSING					NAME Tim Bushman DATE SIGNED Feb 20, 2024			
					NAME Todd Grabowski DATE SIGNED Feb 27, 2024			
					SCALES: HOR. 1:10 VERT. 1:10		PLAN NO. 102-0002-003r002	