

# Lot Draw Addendum

For:



**Evergreen – Phase 7**

**Residential Lot Draw**

---

NEIGHBOURHOOD: Evergreen  
LOCATION: Glacial Shores Common, Manor, Bend, Bay, Cove, Way, and Court; Arscott Crescent and Street.

Addendum No.: 1  
Page: 1 of 7  
Date: November 13, 2013.

Addition to the original Lot Draw Package, released November 12, 2013.

Acknowledgement of receipt of this addendum shall be stated on the Agreement for Sale.

## Individual Lot Grade Drawings

---

Individual Lot Grade Drawings show the final design elevations at property corners and at other points that are deemed critical elevation points. It is important that builders and homeowners match these grades with final landscape elevations. These elevations are required as a minimum for building plan approval.

The attached drawing indicates the individual lot grades for lots located in the following Blocks:

Blocks 658 to 660, Plan 102138599  
Blocks 658, 661 to 663, Plan 102132447  
Block 664 to 665, 667, Plan 102135024

Attachment 1: Individual Lot Grades (6 pages)

KEY PLAN

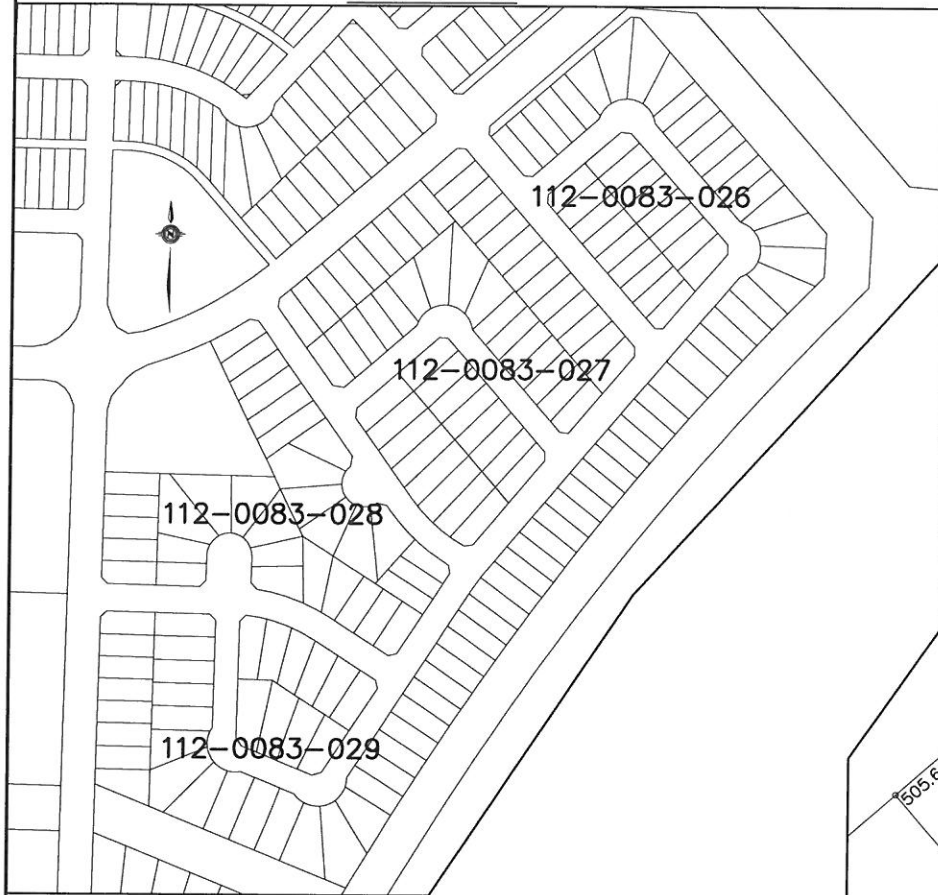

LEGEND

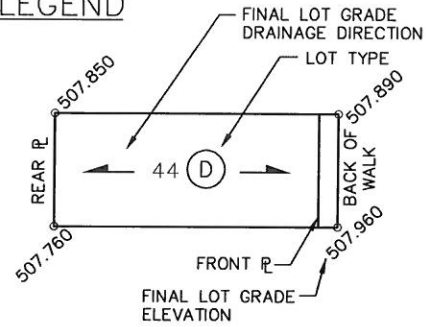

NOTE:

1. LOT GRADES REPRESENT THE DESIGN ELEVATION AT THE BACK OF WALK (B.O.W.)

LOT DRAINAGE DETAILS

- LOT TYPE 'A' - SEE DRAWING 102-0022-016  
 LOT TYPE 'D' - SEE DRAWING 102-0022-017  
 LOT TYPE 'A-D', 'D-A' - SEE DRAWING 102-0022-013



11			
10			
9			
8			
7			
6			
5			
4			
3			
2			
1	DESCRIPTION OF PLAN/REVISION	20YY-MON-DD	XXX
	PLAN DESCRIPTION/REVISION	DATE	BY



CONSTRUCTION & DESIGN	TRANSPORTATION	PUBLIC WORKS	STRATEGIC SERVICES
ENGINEER	ENGINEER	ENGINEER	ENGINEER
DATE	DATE	DATE	DATE
DRAWN BY: KAS	DATE: 2013-SEP-09	CHECKED BY:	DATE:



EVERGREEN ROADWAYS - PHASE C5A	
LOT GRADES GLACIAL SHORES MANOR & COMMON	
GENERAL MANAGER	DATE
SCALES: HOR. 1:1000	DATE
SHEET NO.	PLAN NO.

GENERAL MANAGER	
SCALES: HOR. 1:1000	DATE
SHEET NO.	PLAN NO.
112-0083-026r001	



KEY PLAN



LEGEND

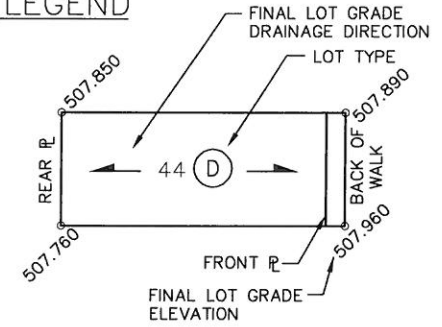

NOTE:

- 1. LOT GRADES REPRESENT THE DESIGN ELEVATION AT THE BACK OF WALK (B.O.W.)

LOT DRAINAGE DETAILS

LOT TYPE 'A' - SEE DRAWING 102-0022-016  
 LOT TYPE 'D' - SEE DRAWING 102-0022-017  
 LOT TYPE 'A-D', 'D-A' - SEE DRAWING 102-0022-013

11			
10			
9			
8			
7			
6			
5			
4			
3			
2			
1	DESCRIPTION OF PLAN/REVISION	20YY-MON-DD	XXX
	PLAN DESCRIPTION/REVISION	DATE	BY



CONSTRUCTION & DESIGN	TRANSPORTATION	PUBLIC WORKS	STRATEGIC SERVICES
ENGINEER	ENGINEER	ENGINEER	ENGINEER
DATE	DATE	DATE	DATE
DRAWN BY: KAS	DATE: 2013-SEP-09	CHECKED BY:	DATE:



EVERGREEN ROADWAYS - PHASE C5A  
 LOT GRADES  
 GLACIAL SHORES MANOR, BEND, WAY & BAY

GENERAL MANAGER	
SCALES:	
HOR. 1:1250	DATE
VERT.	
SHEET NO.	PLAN NO.
	112-0083-027r001





### LEGEND

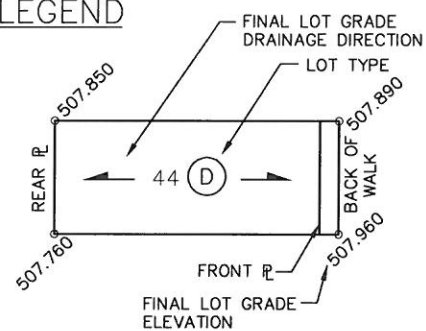

**NOTE:**  
 1. LOT GRADES REPRESENT THE DESIGN ELEVATION AT THE BACK OF WALK (B.O.W.)

### LOT DRAINAGE DETAILS

LOT TYPE 'A' - SEE DRAWING 102-0022-016  
 LOT TYPE 'D' - SEE DRAWING 102-0022-017  
 LOT TYPE 'A-D', 'D-A' - SEE DRAWING 102-0022-013



11			
10			
9			
8			
7			
6			
5			
4			
3			
2			
1	DESCRIPTION OF PLAN/REVISION	20YY-MON-DD	XXX
	PLAN DESCRIPTION/REVISION	DATE	BY



CONSTRUCTION & DESIGN	TRANSPORTATION	PUBLIC WORKS	STRATEGIC SERVICES
ENGINEER _____	ENGINEER _____	ENGINEER _____	ENGINEER _____
DATE _____	DATE _____	DATE _____	DATE _____
DRAWN BY: KAS	DATE: 2013-SEP-05	CHECKED BY: _____	DATE: _____



EVERGREEN ROADWAYS - PHASE C5A  
 LOT GRADES  
 GLACIAL SHORES WAY, BAY, BEND, MANOR & COVE

GENERAL MANAGER _____
SCALES: HOR. 1:1000
VERT. _____
DATE _____
SHEET NO. _____
PLAN NO. 112-0083-028r001

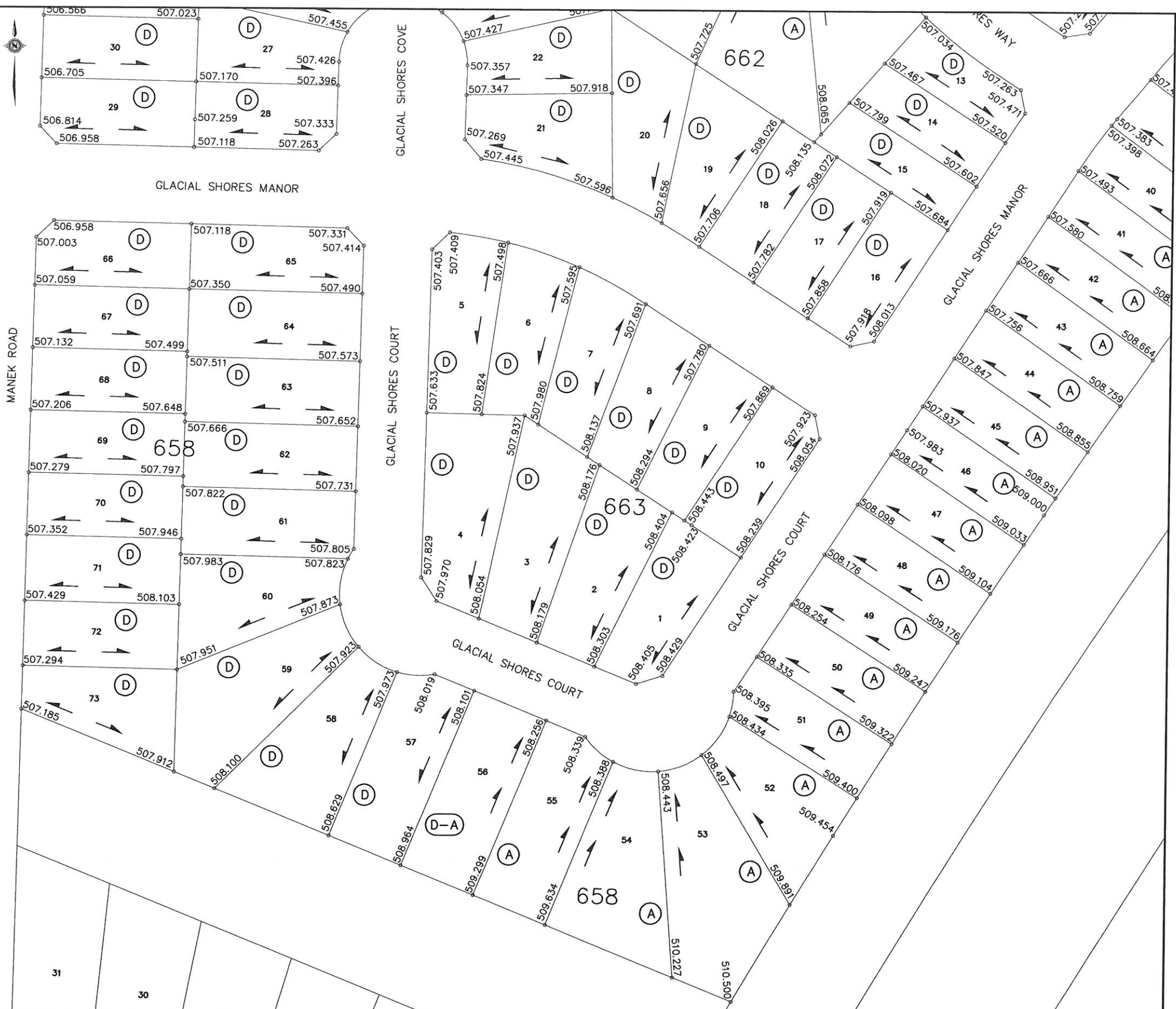
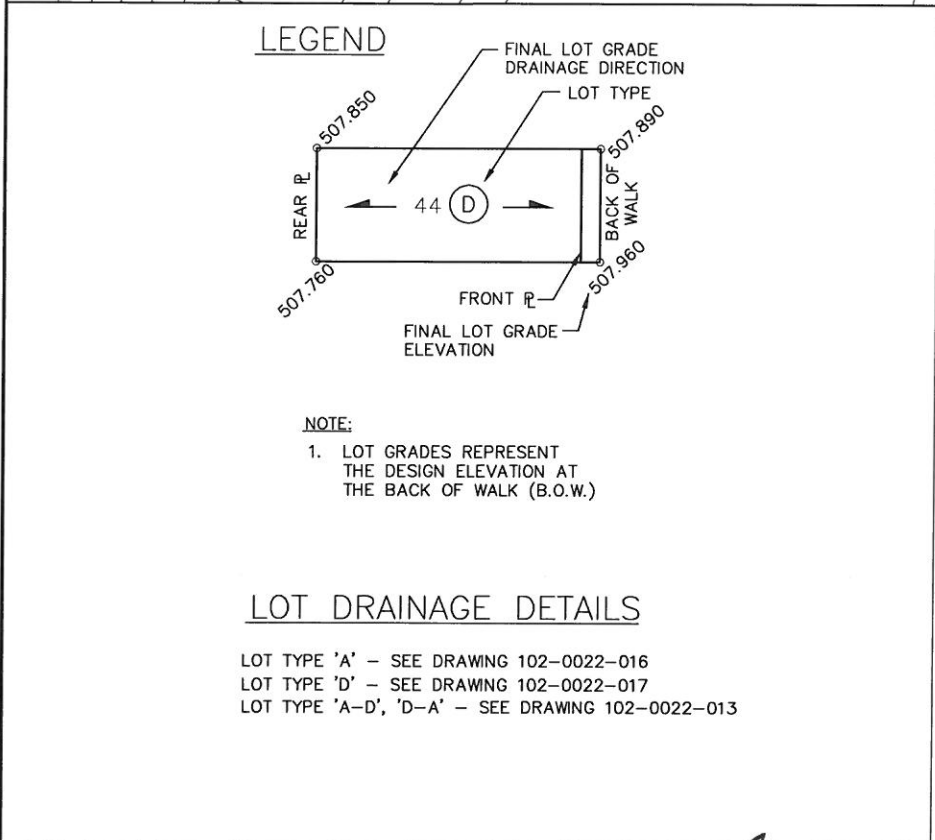
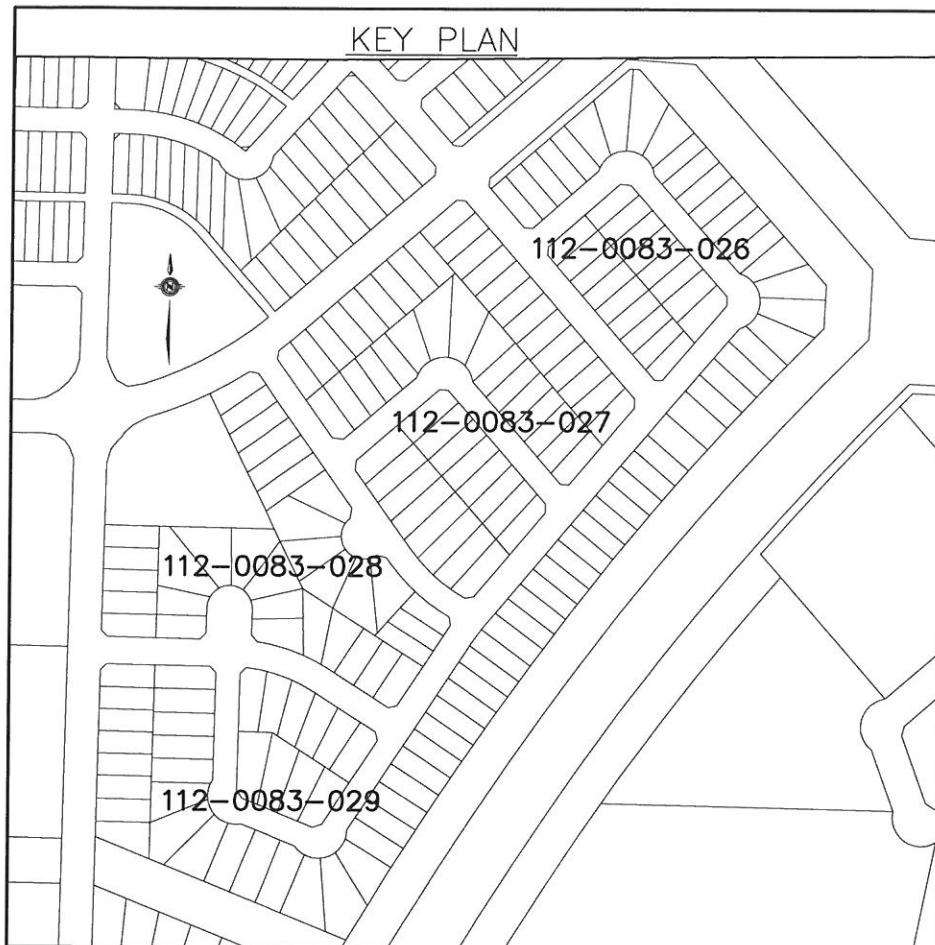

11			
10			
9			
8			
7			
6			
5			
4			
3			
2			
1	DESCRIPTION OF PLAN/REVISION	20YY-MON-DD	XXX
	PLAN DESCRIPTION/REVISION	DATE	BY



CONSTRUCTION & DESIGN	TRANSPORTATION	PUBLIC WORKS	STRATEGIC SERVICES
ENGINEER	ENGINEER	ENGINEER	ENGINEER
DATE	DATE	DATE	DATE
DRAWN BY: KAS	DATE: 2013-SEP-05	CHECKED BY:	DATE:



EVERGREEN ROADWAYS - PHASE C5A

LOT GRADES  
GLACIAL SHORES MANOR, COVE & COURT

GENERAL MANAGER \_\_\_\_\_  
 SCALES: HOR: 1:1000 DATE \_\_\_\_\_  
 VERT: \_\_\_\_\_  
 SHEET NO. PLAN NO.  
 112-0083-029r001

KEY PLAN

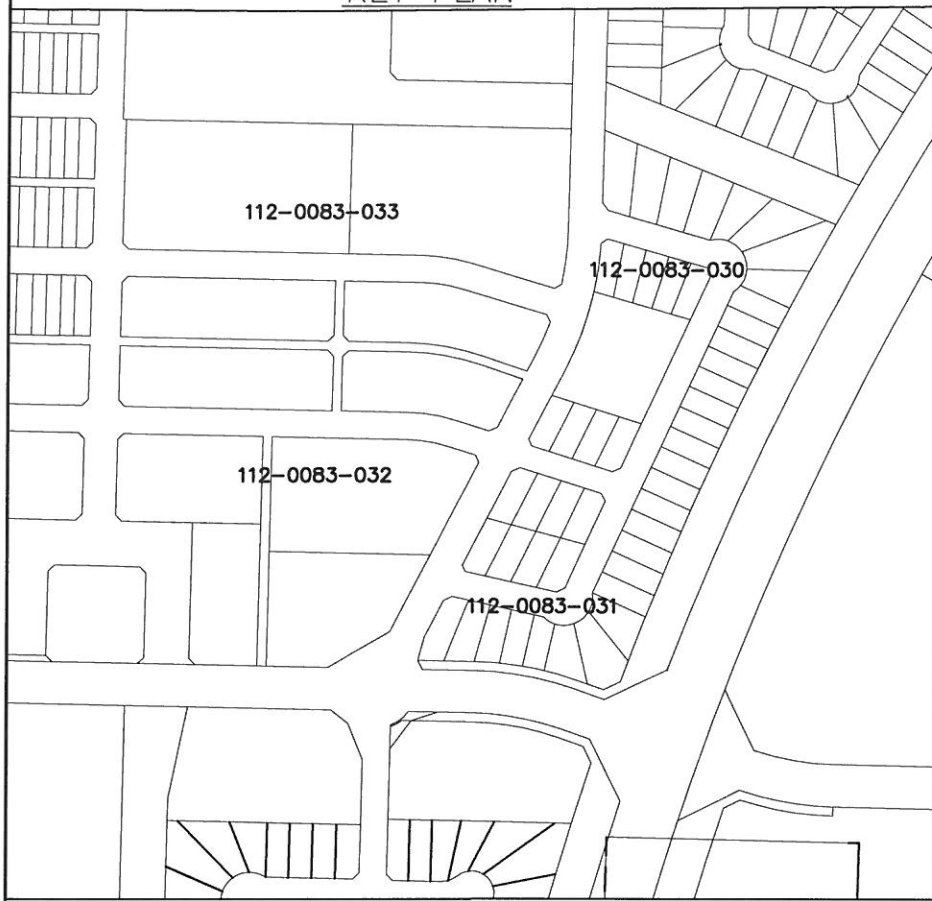

LEGEND

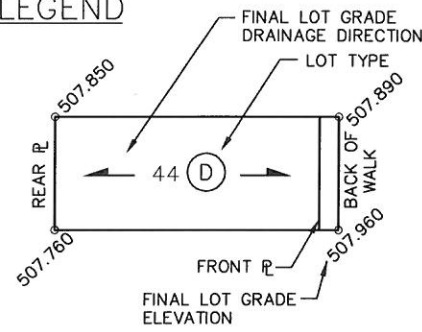

NOTE:

- 1. LOT GRADES REPRESENT THE DESIGN ELEVATION AT THE BACK OF WALK (B.O.W.)

LOT DRAINAGE DETAILS

LOT TYPE 'A' - SEE DRAWING 102-0022-016  
 LOT TYPE 'D' - SEE DRAWING 102-0022-017  
 LOT TYPE 'A-D', 'D-A' - SEE DRAWING 102-0022-013

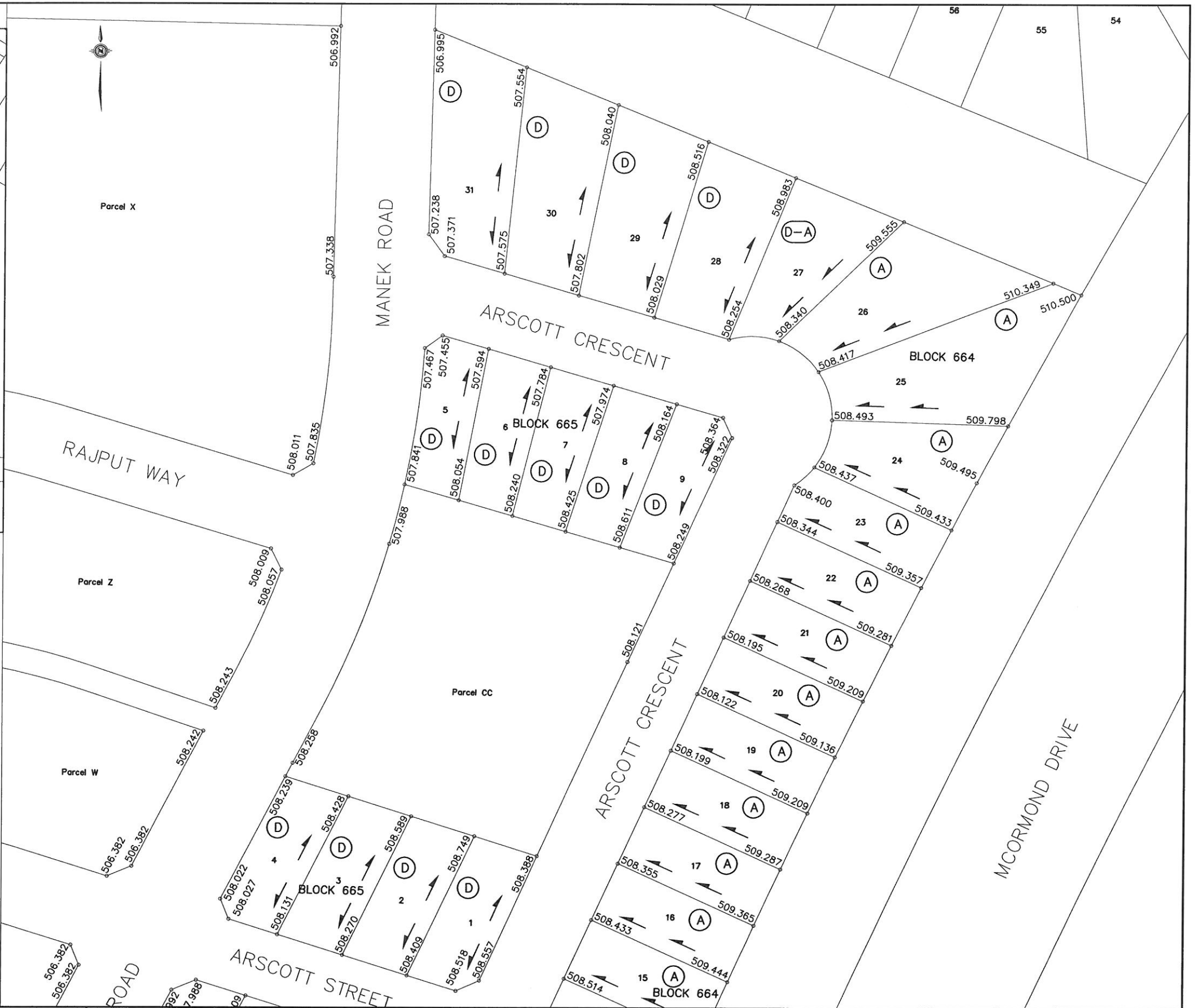

11			
10			
9			
8			
7			
6			
5			
4			
3			
2			
1	DESCRIPTION OF PLAN/REVISION	20YY-MON-DD	XXX
	PLAN DESCRIPTION/REVISION	DATE	BY



CONSTRUCTION & DESIGN	TRANSPORTATION	PUBLIC WORKS	STRATEGIC SERVICES
ENGINEER	ENGINEER	ENGINEER	ENGINEER
DATE	DATE	DATE	DATE
DRAWN BY: KAS	DATE: 2013-OCT-17	CHECKED BY:	DATE:



EVERGREEN ROADWAYS - PHASE C5B  
 LOT GRADES  
 ARSCOTT CRESCENT, STREET & MANEK ROAD

GENERAL MANAGER	
SCALES:	
HOR. 1:1000	DATE
VERT.	
SHEET NO.	PLAN NO.
	112-0083-030r001



KEY PLAN

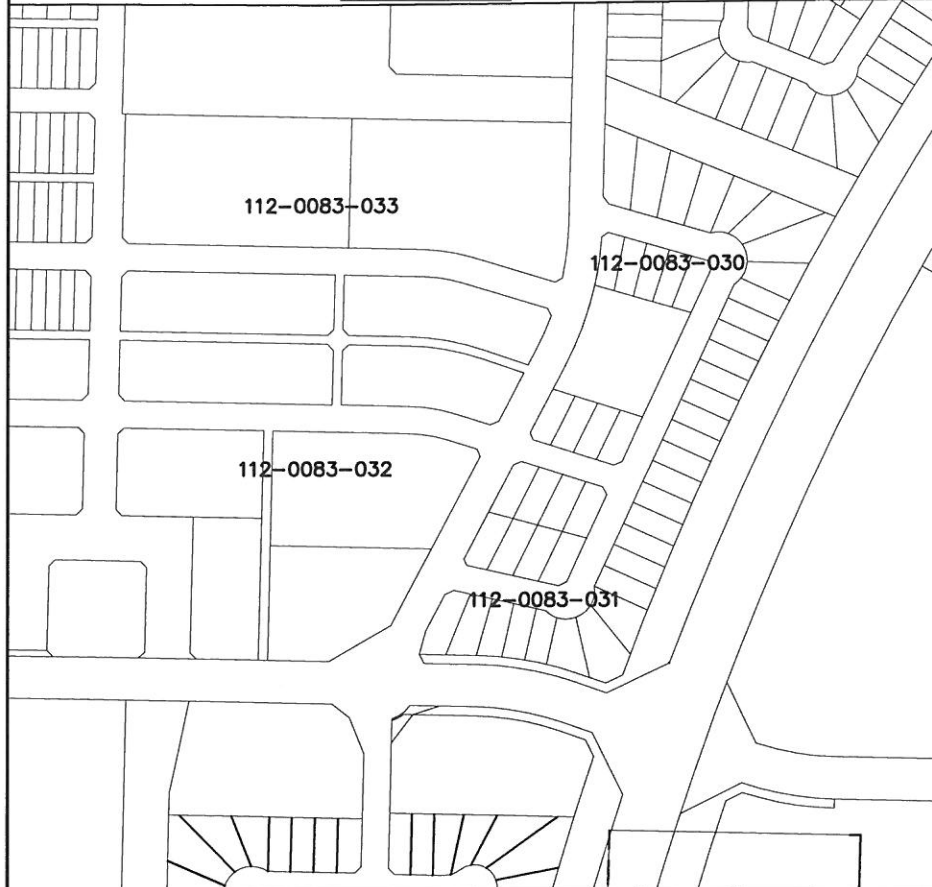

LEGEND

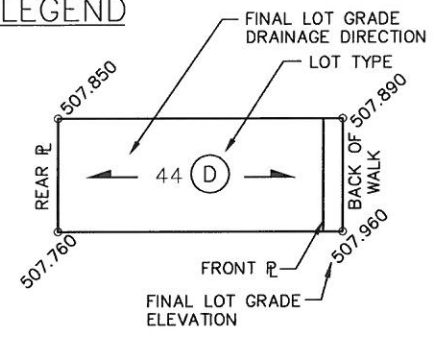

NOTE:  
1. LOT GRADES REPRESENT THE DESIGN ELEVATION AT THE BACK OF WALK (B.O.W.)

LOT DRAINAGE DETAILS

LOT TYPE 'A' - SEE DRAWING 102-0022-016  
LOT TYPE 'D' - SEE DRAWING 102-0022-017  
LOT TYPE 'A-D', 'D-A' - SEE DRAWING 102-0022-013



11			
10			
9			
8			
7			
6			
5			
4			
3			
2			
1	DESCRIPTION OF PLAN/REVISION	20YY-MON-DD	XXX
	PLAN DESCRIPTION/REVISION	DATE	BY



CONSTRUCTION & DESIGN	TRANSPORTATION	PUBLIC WORKS	STRATEGIC SERVICES
ENGINEER	ENGINEER	ENGINEER	ENGINEER
DATE	DATE	DATE	DATE
DRAWN BY: KAS	DATE: 2013-OCT-17	CHECKED BY:	DATE:



EVERGREEN ROADWAYS - PHASE C5B  
LOT GRADES  
ARSCOTT CRESCENT, STREET & MANEK ROAD

GENERAL MANAGER	DATE
SCALES: HOR: 1:1000	DATE
VERT:	DATE
SHEET NO.	PLAN NO.
	112-0083-031r001