

SECTION A-A
SCALE 1:50

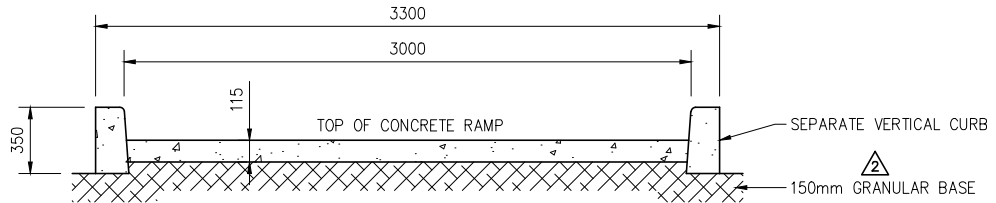

SECTION B-B
SCALE 1:50

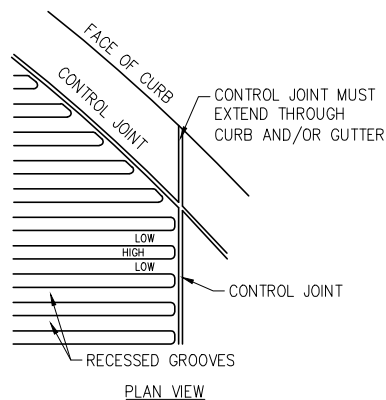

PLAN VIEW

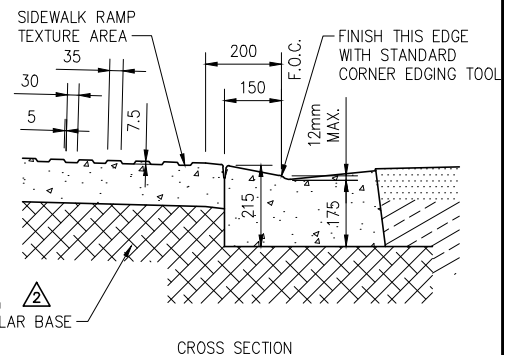

CROSS SECTION

TEXTURE DETAILS
SCALE 1:20

NOTES:

- GROOVES ON TEXTURED AREA ARE TO BE PLACED PERPENDICULAR TO THE CROSSWALK LINES.
- CONTROL JOINTS MUST INTERCEPT THE BOTTOM OF RECESSED GROOVES.
- CONTROL JOINTS MUST BE SLIGHTLY DEEPER THAN RECESSED GROOVES.
- CONCRETE STANDARD:
32 MPa DURA-MIX CONCRETE
5-8% AIR AS PER SPEC.
- COMPACTION STANDARD:
98% STANDARD PROCTOR AS PER SPEC.
- BROOM FINISH CURB FACE & GUTTER.
BROOM OVER ALL CONTROL JOINTS.

PLAN DESCRIPTION/REVISION	DATE	BY
1 ORIGINAL STANDARD DRAWING	2013-JUL-30	JLP
2 UPDATED TO ALIGN WITH SIDEWALK BEST PRACTICES REPORT	2020-OCT-07	DLH

City of Saskatoon
 MEDIAN CUT-THROUGH DETAILS
 PEDESTRIAN OR CYCLIST CROSSING

APPROVALS	
SIGNATURE <i>Chris Duriez</i> Christopher Duriez	SIGNATURE <i>Maciej Jurkiewicz</i> Maciej Jurkiewicz
NAME Jan 25, 2021	NAME Jan 25, 2021
DATE SIGNED	DATE SIGNED
SCALES: HOR. AS NOTED VERT.	PLAN NO. 102-0002-070r002