

PLAN VIEW
SCALE 1:100

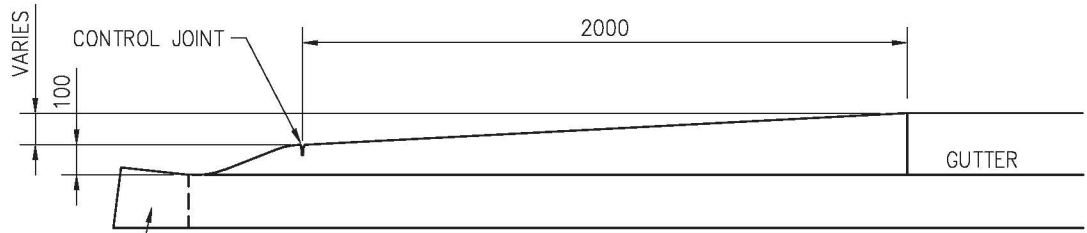

GUTTER OPTIONAL FOR EXISTING
MEDIAN RECONSTRUCTION

PROFILE VIEW OF MEDIAN TIP
SCALE 1:25

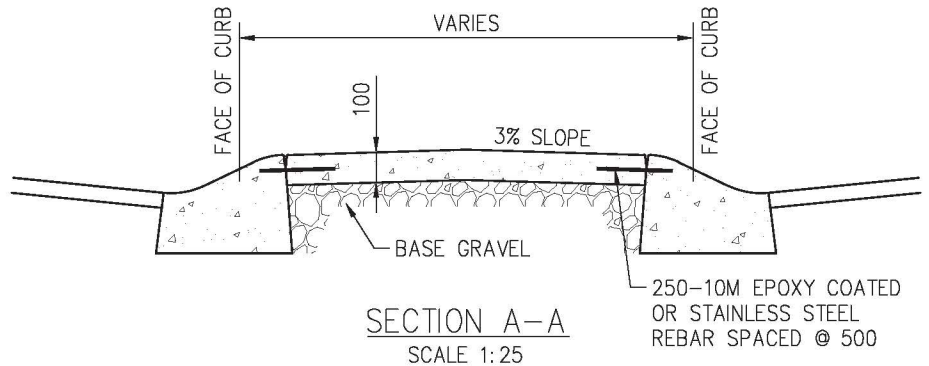

SECTION A-A
SCALE 1:25

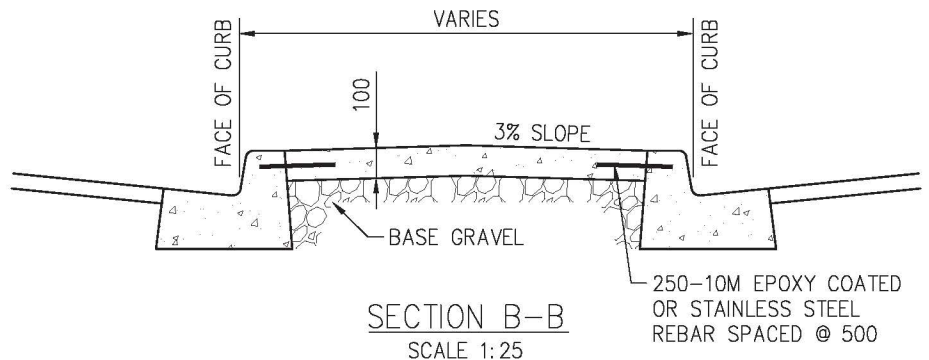

SECTION B-B
SCALE 1:25

NOTES:

1. CONCRETE STANDARD:
32 MPa DURA-MIX CONCRETE
5-8% AIR AS PER SPEC.
2. COMPACTION STANDARD:
98% STANDARD PROCTOR AS PER SPEC.
3. RAISED MEDIANS WITH PORTIONS IN EXCESS OF 2.0m WIDTH SHALL BE LANDSCAPED TO THE REQUIREMENTS OF THE PARKS DIVISION OF THE COMMUNITY SERVICES DEPARTMENT AND SHALL NOT IMPEDE VISIBILITY OF THE INTERSECTION.
4. MEDIANS 2.0m IN WIDTH OR LESS SHALL BE HARD SURFACED THROUGHOUT.

PLAN DESCRIPTION/REVISION	DATE	BY
1 ORIGINAL STANDARD DRAWING	1999-FEB-01	RO
2 UPDATED TO ALIGN WITH THE DESIGN & DEVELOPMENT STANDARDS	2020-FEB-13	PRZ
2 MANUAL AND POLICY C07-030 - STREET DESIGN	2020-FEB-13	PRZ

**City of
Saskatoon**
 MOUNTABLE MEDIAN TIP

APPROVALS	
 Chelsea Lanning (Apr 23, 2020) SIGNATURE Chelsea Lanning NAME Apr 23, 2020 DATE SIGNED	 SIGNATURE Matt Jurkiewicz NAME Apr 30, 2020 DATE SIGNED
SCALES: HOR. AS NOTED VERT.	PLAN NO. 102-0006-002r002