

PROFILE

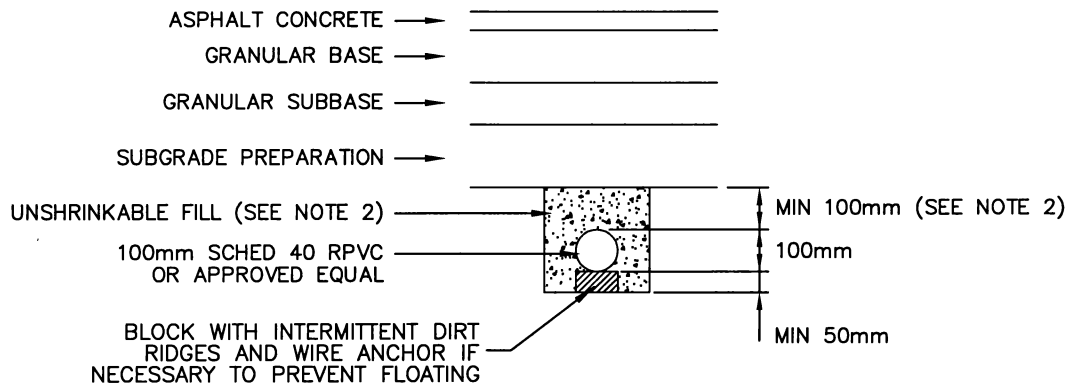

SECTION A-A

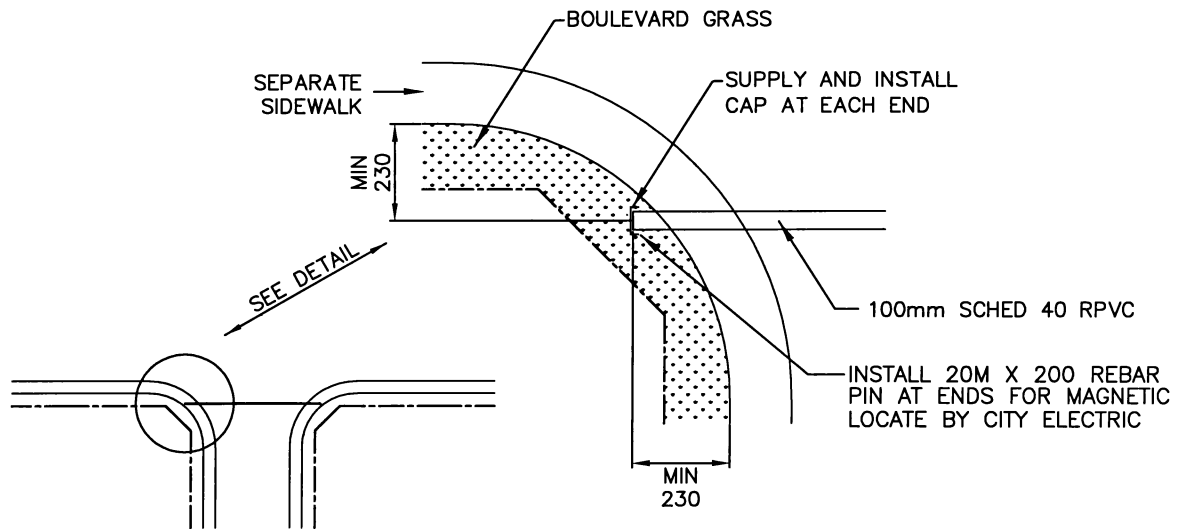

TYPICAL PLAN

NOTES:

1. PULL ROPE MUST BE INSTALLED IN SLEEVE (1/4" POLY ROPE OR APPROVED EQUAL)
2. UNSHRINKABLE FILL MAY EXTEND TO UNDERSIDE OF SUBBASE IF INSTALLED AFTER SUBGRADE PREPARATION
3. UNSHRINKABLE FILL AS PER STANDARD SPECIFICATIONS DIV. 8 SEC. 08000
4. AFTER BACKFILL, PULL 75mm MANDRELL THROUGH SLEEVE IN PRESENCE OF ENGINEER

REVISIONS	
1	
2	
3	



City of Saskatoon
Infrastructure Services Department

APPROVED
[Signature] P. ENG.
GENERAL MANAGER
A. Boyko
ENGINEER

DRAWN BY A. YOUNG
DATE 2003-02-25
CHECKED BY _____
DATE _____

TYPICAL ROADWAY CROSSING ELECTRICAL SLEEVE

ENGINEER _____
SCALES : HOR. NTS _____
PLAN NO. 102-0007-006r001