

PLAN VIEW

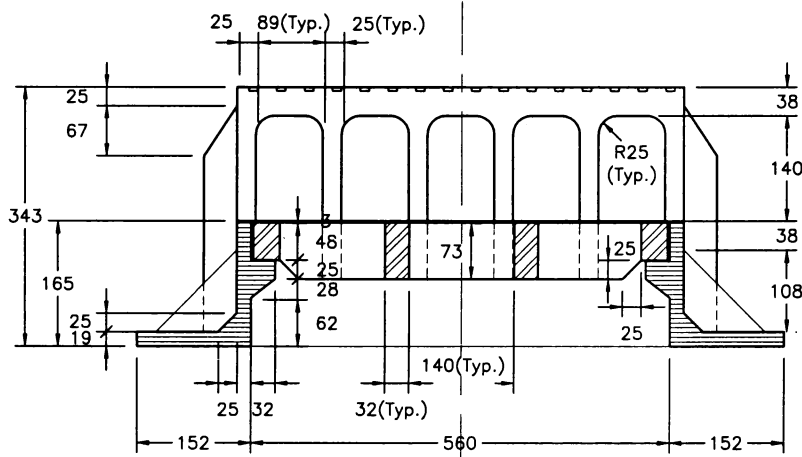

SECTION 'A' - 'A'

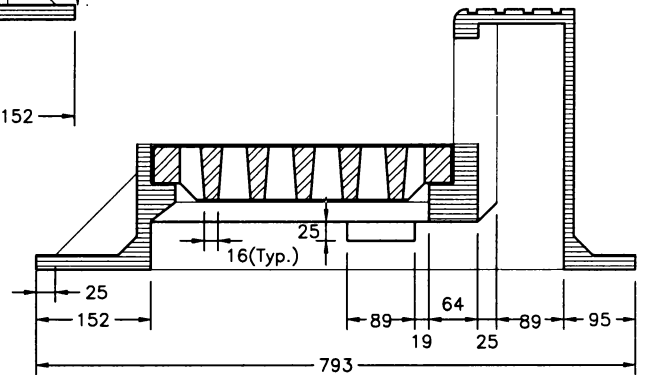

SECTION 'B' - 'B'

SPECIFICATIONS :

THE CASTINGS SHALL BE TRUE TO PATTERN AND FREE FROM CRACKS, GAS HOLES, FLAWS, AND EXCESSIVE SHRINKAGE. SURFACES OF THE CASTINGS SHALL BE FREE FROM BURNT ON SAND AND SHALL BE REASONABLY SMOOTH. RUNNERS, RISERS, FINS, AND OTHER CAST ON PIECES SHALL BE REMOVED. IN OTHER RESPECTS THE CASTINGS SHALL CONFORM TO WHATEVER POINTS MAY BE AGREED UPON BETWEEN THE MANUFACTURER AND THE ENGINEER.

REVISIONS	
1	
2	
3	

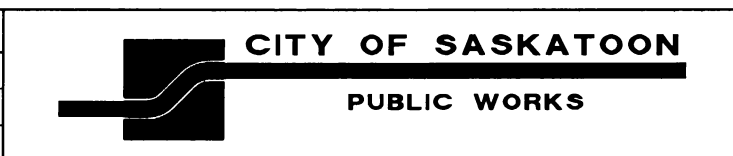

APPROVED	
GENERAL MANAGER	P. ENG.
<i>A. Boyle</i>	
ENGINEER	

DRAWN BY	JB
DATE	99-02-18
CHECKED BY	
DATE	

CATCH BASIN FRAME AND COVER
CURB INLET MODEL

ENGINEER	
SCALES :	HOR. 1:10 VERT. _____
PLAN NO.	102-0010-005r001