

SPECIFICATIONS

- (1) CASTINGS SHALL CONFORM TO ALL REQUIREMENTS OF A.S.T.M. DESIGNATION A48 CLASS 30
- (2) CASTINGS SHALL BE PRODUCED TO THE DIMENSIONS AND WITHIN THE TOLERANCES NOTED IN THE TABLE I.
- (3) CASTINGS SHALL BE MARKED WITH THE PROPER IDENTIFICATION MARKINGS WHICH WILL INCLUDE:
 - (a) MARKINGS AS REQUESTED AT TIME OF ORDER.
 - (b) FOUNDRY IDENTIFICATION MARKING, AND YEAR OF CASTING.
 - (c) THESE MARKINGS SHALL BE SO LOCATED IN SUCH A MANNER AND OF SUCH SIZE THAT THEY ARE EASILY IDENTIFIABLE AFTER INSTALLATION.
- (4) ALL CASTING WILL BE FREE OF DEFECTS, BE TRUE TO PATTERN AND BE FREE FROM CRACKS, GAS HOLES, FLAWS AND EXCESSIVE SPRINKAGE. SURFACES OF CASTING SHALL BE FREE FROM BURNT ON SAND AND SHALL BE REASONABLY SMOOTH.
- (5) CASTING SHALL NOT ROCK WHEN INSTALLED. THE MANUFACTURER SHALL TRIAL FIT THE CASTINGS AGAINST A STANDARD FRAME.

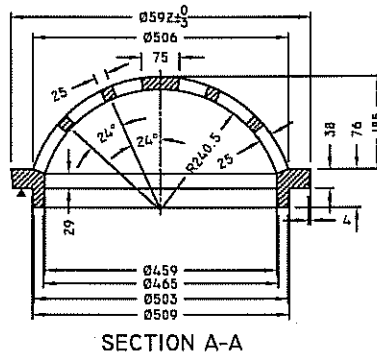

▼ - BEARING SURFACES
MEASUREMENTS IN MILLIMETERS

TABLE I
MANUFACTURING TOLERANCE

ALL DIMENSIONS SHALL CONFORM TO ±2MM TOLERANCE EXCEPT:
(1) AS NOTED.
(2) NO DEVIATION SHALL BE ACCEPTABLE FOR DIMENSIONS WHICH ARE LESS THEN 10MM

REVISIONS	
1	
2	
3	
DRAWN BY <u>MLB</u>	
DATE <u>08-11-21</u>	
CHECKED BY _____	
DATE _____	



City of Saskatoon
Infrastructure Services Department

TF-101 BEEHIVE GRATE

APPROVED	
<i>[Signature]</i>	<i>[Signature]</i>
GENERAL MANAGER	P. ENG.
ENGINEER -	<i>[Signature]</i>
ENGINEER	<i>[Signature]</i> Nov 21, 08
SCALES :	HOR. 1:15
PLAN NO. 102-0011-026r001	