

BEARING AREA OF BLOCKS IN SQ. METERS

DWG. NO.	PIPE SIZE						
	100	150	200	250	300	350	400
1, 4, 12	.186	.372	.650	1.022	1.440	1.952	2.602
3, 5, 7	.279	.511	.883	1.440	2.045	2.695	3.532
2	.093	.139	.232	.325	.465	.697	.929
6, 8, 11	.139	.279	.465	.604	1.115	1.394	1.859
10	.093	.139	.279	.418	.588	.836	1.115
9	.279	.558	.976	1.162	2.184	2.974	3.903

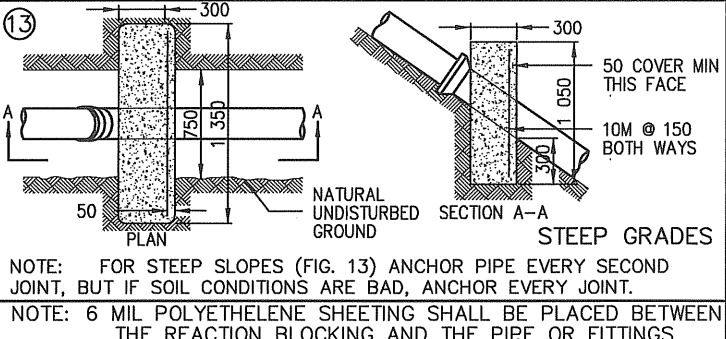

REVISIONS	
1	ADDED 6 MIL POLY REQUIREMENT HLO 2010-12-14
2	
3	

DRAWN BY JLL
DATE 1996-03-05

City of Saskatoon
Infrastructure Services Department

REACTION BLOCKING AND WATER MAIN ANCHORING

GENERAL MANAGER _____ P. ENG.
ENGINEER _____
SCALES: HOR. 1:50 VERT. _____
PLAN NO. 102-0012-002r002