

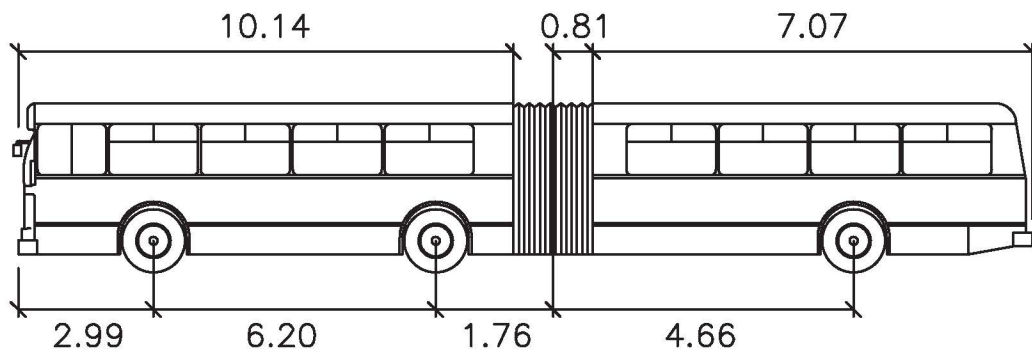

<u>VEHICLE NAME</u>	<u>NOVA LFS 60</u>
<u>SOURCE LIBRARY: AUTOTURN 10.2</u>	COS CUSTOM VEHICLES
<u>VEHICLE TYPE</u>	ARTICULATING BUS
<u>CLASS</u>	BUS
<u>LOCK TO LOCK TIME</u>	6.0 SEC.
<u>STEERING LOCK ANGLE</u>	40.0 DEGREES
<u>ARTICULATING ANGLE</u>	50.0 DEGREES
<u>UNITS OF MEASURE</u>	METERS
<u>OVERALL VEHICLE LENGTH</u>	18.83
<u># OF AXLES</u>	3
<u>TRACTOR WIDTH</u>	2.60
<u>MIN. TURNING RADIUS BASED ON CENTERLINE</u>	10.57 @ 90 DEGREES
<u>FRONT OVERHANG</u>	2.99
<u>REAR OVERHANG</u>	3.22



PLAN DESCRIPTION/REVISION			DATE	BY	APPROVALS	
1	ORIGINAL STANDARD DRAWING		2020-FEB-13	S.K		
					 Chelsea Lanning (Apr 23, 2020) SIGNATURE	
					Chelsea Lanning NAME Apr 23, 2020 DATE SIGNED	
					Matt Jurkiewicz NAME Apr 30, 2020 DATE SIGNED	
					SCALES: HOR. N.T.S. VERT.	PLAN NO. 102-0029-050r001
					DESIGN VEHICLE ARTICULATING BUS	