

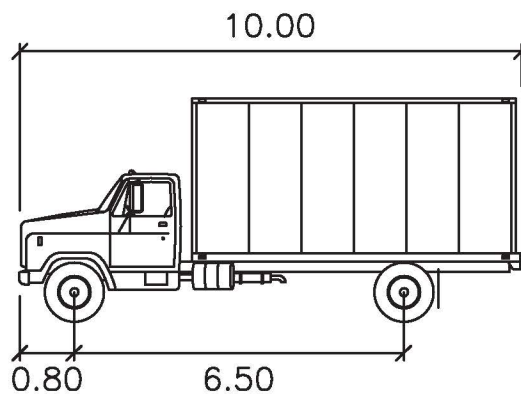



<u>VEHICLE NAME</u>	<u>MSU</u>
<u>SOURCE LIBRARY: AUTOTURN 10.2</u>	CANADIAN DESIGN VEHICLES
<u>VEHICLE TYPE</u>	MEDIUM SINGLE UNIT TRUCK
<u>CLASS</u>	COMMERCIAL TRUCK
<u>LOCK TO LOCK TIME</u>	4.0 SEC.
<u>STEERING LOCK ANGLE</u>	40.2 DEGREES
<u>UNITS OF MEASURE</u>	METERS
<u>OVERALL VEHICLE LENGTH</u>	10.00
<u># OF AXLES</u>	2
<u>TRACTOR WIDTH</u>	2.60
<u>MIN. TURNING RADIUS BASED ON CENTERLINE</u>	10.05 @ 90 DEGREES
<u>FRONT OVERHANG</u>	0.80
<u>REAR OVERHANG</u>	2.70



PLAN DESCRIPTION/REVISION			DATE	BY	APPROVALS	
1	ORIGINAL STANDARD DRAWING		2020-FEB-13	S.K		
					 Chelsea Lanning (Apr 23, 2020) SIGNATURE Chelsea Lanning	
					 NAME Apr 23, 2020 DATE SIGNED	
					NAME Apr 30, 2020 DATE SIGNED	
					SCALES: HOR. N.T.S. VERT.	PLAN NO. 102-0029-051r001
					DESIGN VEHICLE MEDIUM SINGLE UNIT TRUCK (MSU)	