



Guidelines

Dry Barrel

HYDRANT

TU-Construction & Design

CONTENTS

Overview.....	1
Scope	1
Guidance Manuals and Publications	1
City of Saskatoon Std. Construction Specifications References	1
Hydrants	2
City of Saskatoon Approved hydrants	5
Installation of hydrants	6
Purpose and uses of fire hydrants	8
Dynamics of Water	8
Planning	9
Hydrant Inspection	9
Fire Flow Testing	12
Environment impact	15
Inspection form	16
Flow calculations	17
Glossary	19

OVERVIEW

The City of Saskatoon has over 7500 public fire hydrants. All public fire hydrants are operated, maintained and inspected by the Public Works division. The Construction and Design (C&D) division has prepared this document to provide guidance for conducting fire flow tests and inspections of public hydrants. This information may also be used as guidance for the inspection, operation and maintenance of privately-owned hydrants connected to the City of Saskatoon water distribution system.

SCOPE

This document is intended to provide guidelines for inspection and fire flow testing of public owned fire hydrants. In no way will this document replace proper training and experience. It should not be viewed as a training manual but as a guide to the equipment. Expertise is required for the proper execution of these functions.

GUIDANCE MANUALS AND PUBLICATIONS

The following publications should be used when installing, testing or inspecting fire hydrants. These publications were also used in the preparation of this document.

Installation, Field Testing, and Maintenance of Fire Hydrants (AWWA M17)
 Recommended Practice for Fire Flow Testing and Marking of Hydrants (NFPA 291)
 AWWA Standard for Disinfecting of Water Mains (C651-05)
 AWWA Standard for Dry Barrel Fire Hydrants (C502-94)
 WSA guide to Water Works Design EPB-201 (2012)
 City Of Saskatoon's approved hydrant manuals
 Information from various websites

CITY OF SASKATOON STANDARD CONSTRUCTION SPECIFICATION REFERENCES

Refer to the following City of Saskatoon Standard Construction Specification and Drawings for:

Relevant Sections	08001-4, 08030-10, 15001-6 & 08030-12 sub-sect: 12.2.4
Hydrant Standard Installation	102-0012-003r004
Square Hydrant Guard	102-0012-004r002
Circular Hydrant Guard	102-0012-012r003
Fire Hydrant Standard Locations	102-0012-016r001

HYDRANTS

A fire hydrant is an active fire protection measure, and a connection point by which firefighters can tap into a water supply. Fire hydrants spend most of their time unused and ignored, yet they are called upon in a moment's notice to provide fire flow for the protection of a business or home. They are an indispensable facet of the overall fire protection features of a building. These hydrants are required for the fire protection of a building, but they are useless unless regularly maintained. Furthermore, they should be painted as described in division 8, sub section 08001-4 of the City of Saskatoon latest edition of Standard Construction Specifications and Drawing so that firefighters can quickly identify the system capability of the hydrant.

The owner is responsible for testing, maintenance and marking of privately- owned fire hydrants and assumes all liability for the proper operation, maintenance, and marking of private hydrants. Maintenance, testing and inspection of private hydrants may only be performed by a contractor registered with the City of Saskatoon.

TYPE OF HYDRANTS

Hydrants are generally classified in two categories:

1. WET BARREL HYDRANTS

Wet barrel hydrants are manufactured in accordance with AWWA Standard C-503. A wet barrel hydrant has a main valve located on each outlet nozzle. The entire hydrant is full of water at all times.

2. DRY BARREL HYDRANTS

Dry barrel hydrants are manufactured in accordance with AWWA standard C-502. Dry barrel hydrants have the main valve located below ground and the section that extends above ground is void of water except during operation. These hydrants are also equipped with drain valves, which allow the entire portion of the hydrant that extends above the main valve to be automatically drained when the hydrant is not in use.

TYPES OF DRY BARREL HYDRANTS

- a. Compression type
- b. Toggle Type
- c. Slide gate type
- d. Special type
 - i. Flush hydrants
 - ii. Frost jacket hydrants
 - iii. High pressure hydrants
 - iv. High pressure pilot-valve hydrants.

Generally compression type dry barrel hydrants are used in the City of Saskatoon.

CROSS SECTION OF TYPICAL DRY BARREL HYDRANT

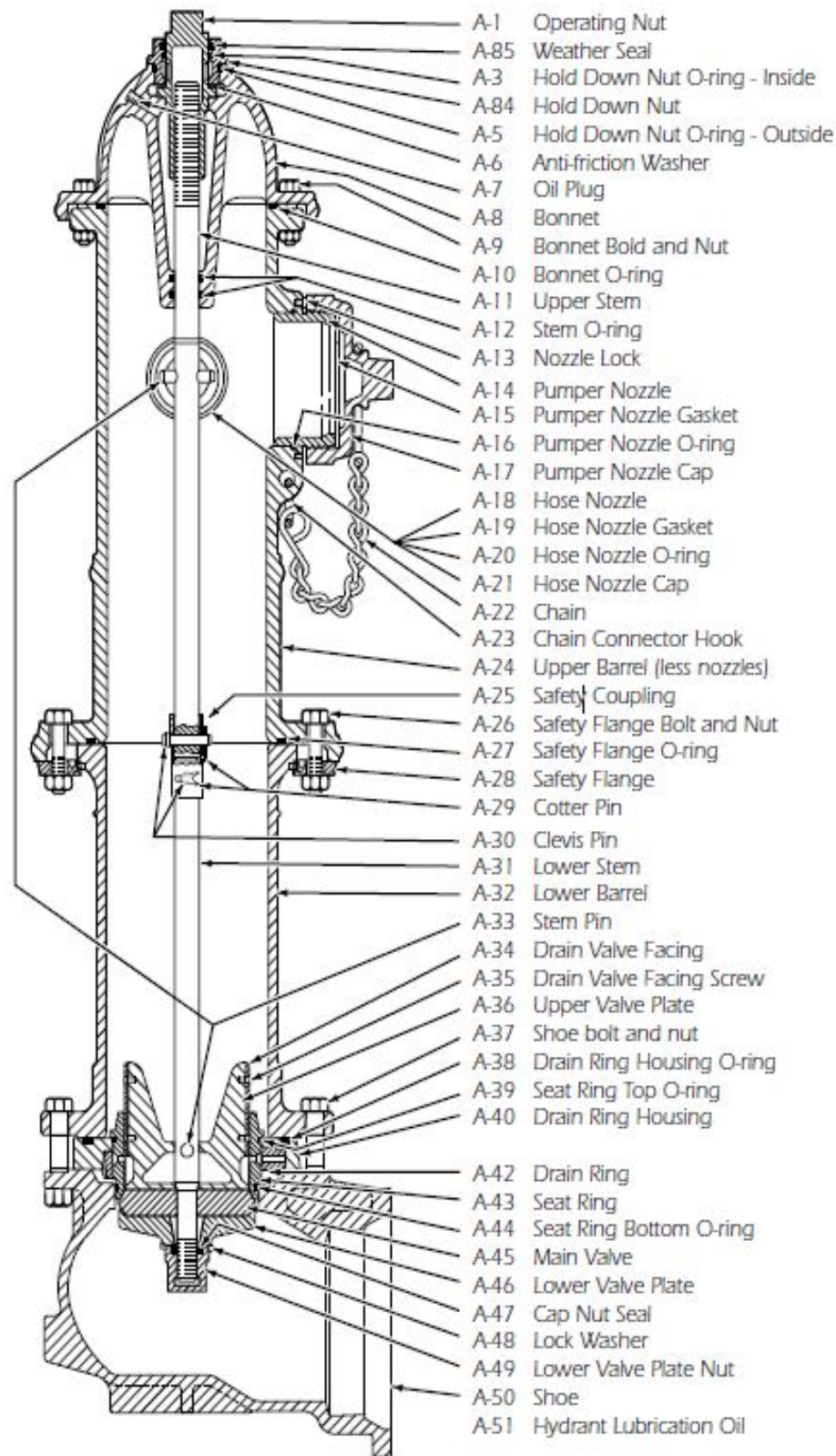



CITY OF SASKATOON APPROVED FIREHYDRANTS

- Mueller Canada – Super Centurion
- Mueller Canada – Modern Centurion
- Mueller Canada – Canada Valve
- Clow Canada – McAvity M67
- Clow Canada (Concorde, Daigle) – D67M



Clow Canada – McAvity



Mueller Canada – Super Centurion



Mueller Canada – Modern Centurion

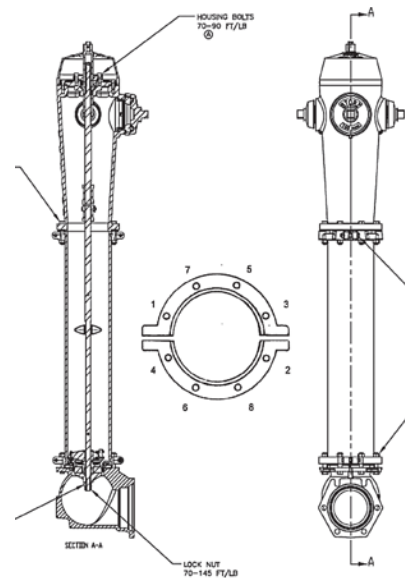

Mueller Canada – Canada Valve

HYDRANT INSTALLATION

TYPICAL INSTALLATION

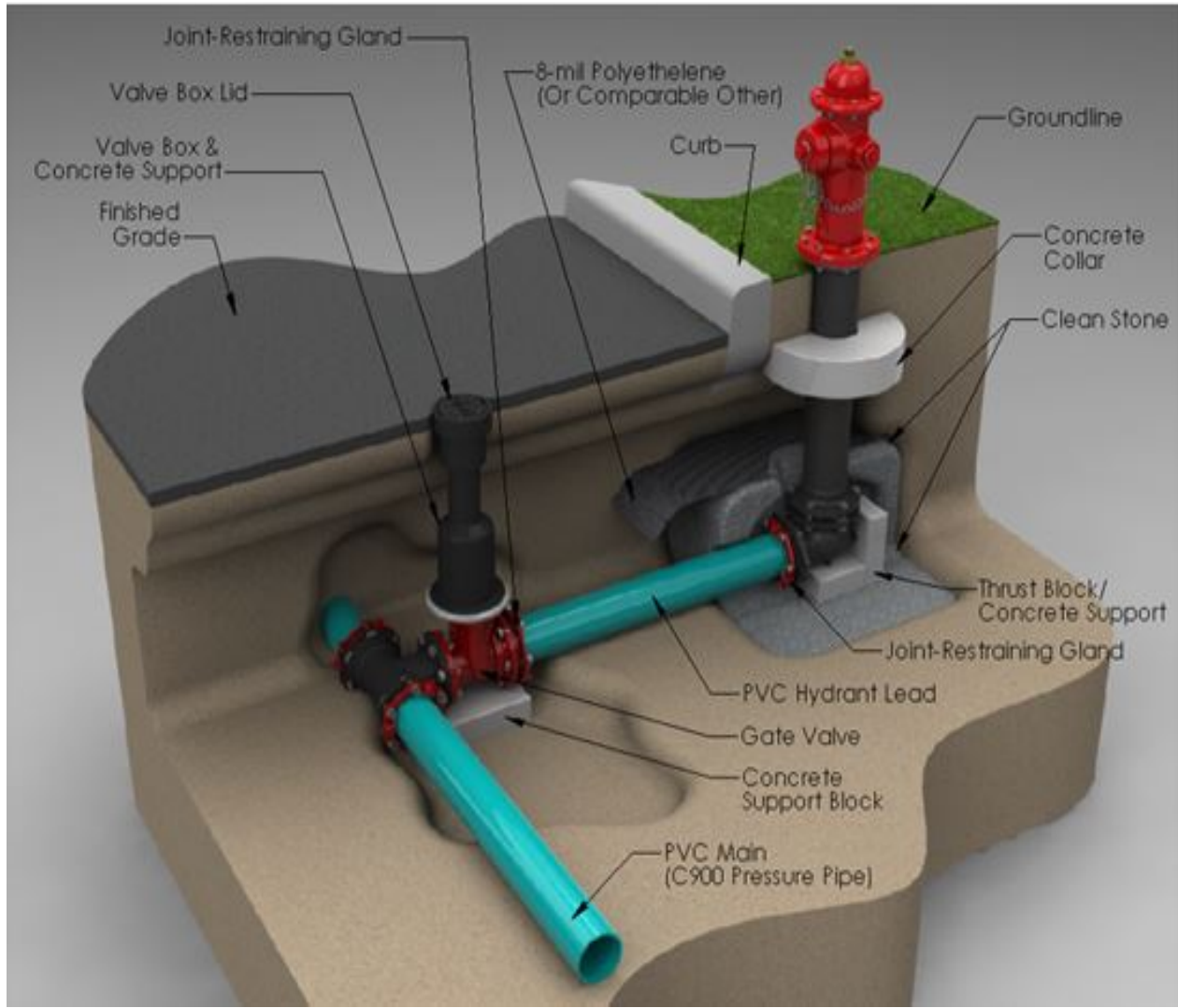

CITY OF SASKATOON STANDARD HYDRANT INSTALLATION

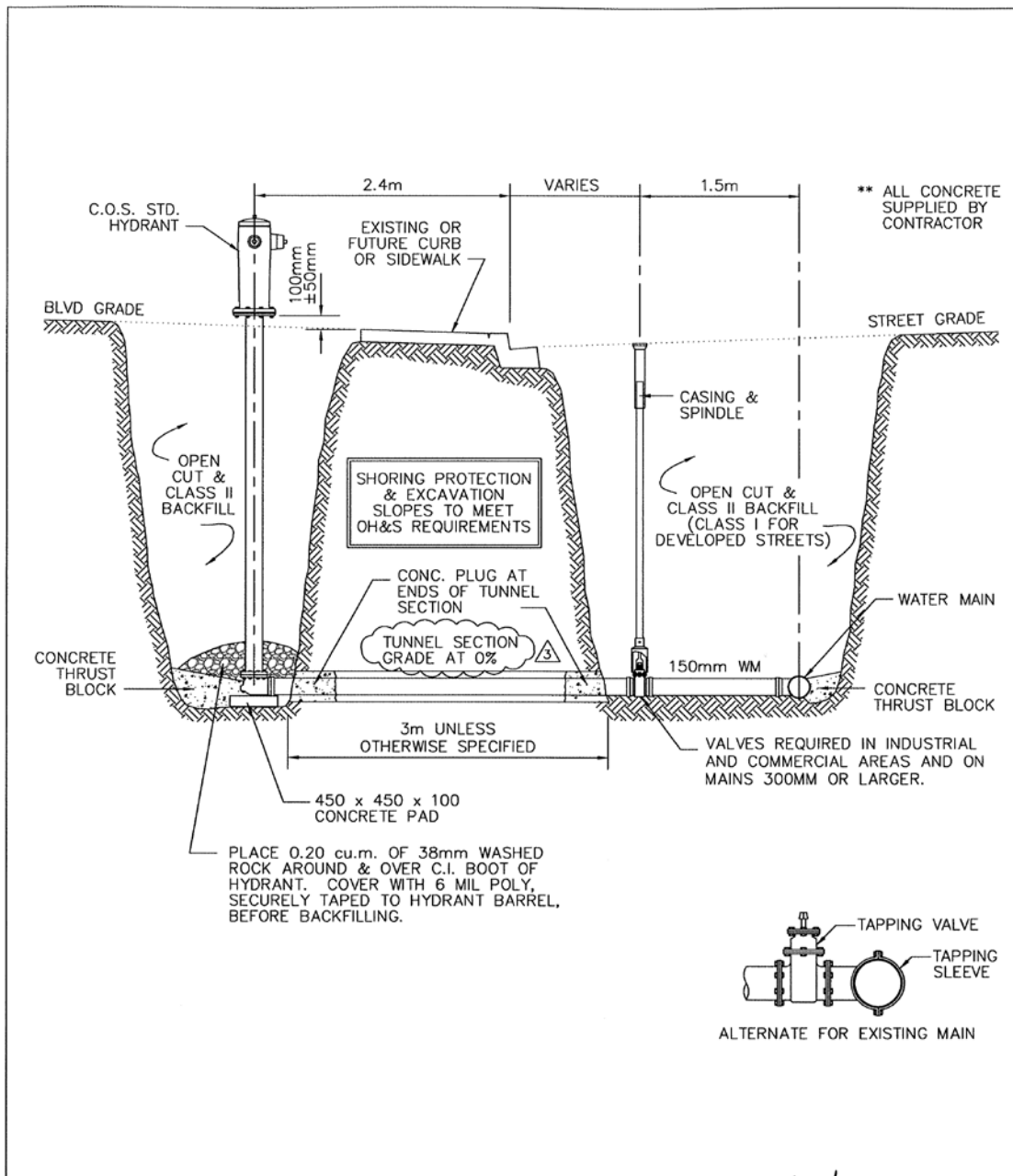

ALL DIMENSIONS IN MILLIMETRES UNLESS OTHERWISE NOTED

REVISIONS 1 MJ 2006-06-22 2 HLO 2012-01-05 3 SPECIFIED TUNNEL SECT. GRADE JAB - 2013 DEC 16			APPROVED _____ GENERAL MANAGER P. ENG.	
DRAWN BY <u>JLL</u> DATE <u>96-03-05</u> CHECKED BY _____ DATE _____			ENGINEER <u>[Signature]</u> ENGINEER _____ SCALES : HOR. _____ VERT. NTS _____ PLAN NO. 102-0012-003r004	
FIRE HYDRANT STANDARD INSTALLATION				

PURPOSE AND USES OF FIRE HYDRANTS

FIRE SUPPRESSION

Although fire hydrants are often used for other purposes, their primary function is to supply water for fire protection. Any other use is considered of secondary importance and rigorously controlled for the protection of the water distribution system.

LINE FLUSHING

The fire hydrants ease of operation and high flow capability make it a natural for use in flushing distribution system main lines. When line flushing is done in conjunction with systematic hydrant inspection, the primary function of the fire hydrant is kept in proper perspective.

TESTING SYSTEM

The City of Saskatoon often uses fire hydrants to test the hydraulic capabilities of the distribution system. These tests, like line flushing, should be conducted in conjunction with tests to evaluate distribution system flow capacities in accordance with fire flow requirements as well as customer flow and pressure needs.

OTHER USES

Fire hydrants are also commonly used as a water source for street cleaning, sewer cleaning, commercial construction, street construction, and as a water source for other commercial applications.

DYNAMICS OF WATER

It is very important to understand dynamics of water prior to performing any sort of flow test or exercising of hydrants, there are several important concepts that must be understood to avoid causing damage to the hydrants and to the water system.

WATER HAMMER

Water hammer is caused by an abrupt change in the velocity of flowing water. It is most often the result of shutting down a valve too quickly. Water is incompressible. It will not absorb ANY of the energy it gives off by being forced to suddenly decelerate. Therefore, the system, pipes, hydrants, and ground have to absorb all of the energy. If a valve is shut down too quickly, the weak link in the system will go first. The weak links are almost always at the flanges, or pipe joints.

BROWN WATER

During normal conditions, water flows through the center portion of a water main because of friction between water and the wall of the pipe; it is easier for the center portion to flow than the outer portion. As the average velocity increases, so too will the velocity of the water close to the wall of the pipe. As this water moves faster, it begins to kick up sediment that usually stays at the bottom of the pipe. This sediment gets stirred up and does not settle back down until the

velocity slows. Once the sediment has been kicked up into the center portion of the pipe, it is now in the main stream of flow. This phase is called Brown water. Sudden change in the amount of flow in water main, such as when operating a fire hydrant often causes Brown water.

PLANNING

It is very important to plan ahead when conducting inspection or fire flow testing. Review distribution-system maps and determine which hydrants will be used to measure flow and which will be used to measure the static and residual pressures. Review previous tests if available, to estimate the flow and pressures that can be expected. Select a day for testing when system consumption will be normal and weather predictions indicate that conditions will be reasonable. The Connections Desk (306 975 XXXX) should be notified and coordinated to book the inspection on the desired date and time. As flow testing can greatly increase the velocity in the main, this may cause discolored water complaints. The residents in the affected area must be notified of potential water quality issues in advance of the testing. Investigate traffic patterns, as the tests may affect traffic flow.

HYDRANT INSPECTION

PERSONAL PROTECTIVE EQUIPMENT

The following PPE is required to perform the task:

1. CSA approved steel toe shoes
2. CSA-Z96 approved high visible/ reflective vest
3. Hard Hat
4. Safety glasses (optional)

INSTRUMENTS & TOOLS

1. Hydrant wrench
2. Discharge diffuser with flexible hose
3. Gate valves
4. Pressure gauges
5. Pitot Tube
6. Electronic meter reading devices (if available)
7. Dechlorination equipment (if required)

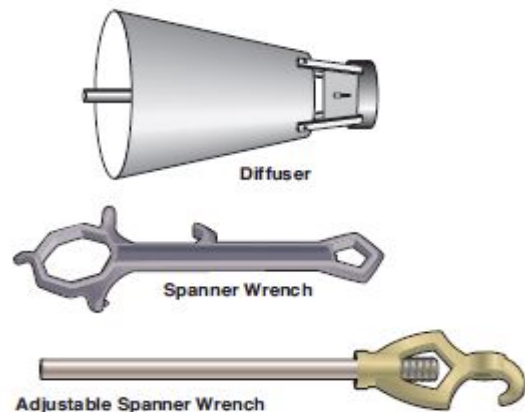

PROCEDURE

Notes:

- ✓ A check list is included at the end of this document
 - ✓ Locate and exercise the auxiliary valve. Leave it in the open position
1. Notify PW CSC (Customer Service Call Centre (306 975 2476)) OR Connections Desk at 306 975 1475 or email connections@saskatoon.ca of the area(s) you will be in prior to beginning.
 2. Check the appearance of the hydrant. Remove obstructions around it. Hydrants are required to have a minimum of 3 feet of clearance in all directions. Check to see whether the hydrant needs to be raised or lowered (pumper nozzle cap should be no less than 18" and no more than 24" from grade) because of a change in the ground-surface grade. Identify other physical features in appropriate columns of inspection sheet.
 3. Check the breakaway device for damage.
 4. Remove one outlet nozzle cap and use a listening device to check main valve for leakage.
 5. Check for the presence of water or ice in the hydrant barrel, by use of a plumb bob or other suitable means.
 6. Replace the outlet nozzle cap. Leave it loose enough to allow air to escape.
 7. Open the hydrant SLOWLY approximately 3 to 5 turns allowing time for air to escape from the hydrant barrel through outlet nozzle cap. (Note: If the hydrant is inoperable, tag it with a clearly visible marker and notify PW CSC/ Connections Desk.)
 8. Tighten the outlet nozzle cap.
 9. With the hydrant fully open, check for leakage at flanges, around outlet nozzles, at packing or seals, and around the operating stem.
 10. Partially close the hydrant so the drains open and water flow through under pressure for about 10 sec, flushing the drain outlets.
 11. Close the hydrant completely. Back off the operating nut enough to take pressure of the thrust bearing and packing (about ¼ turn).
 12. Remove the outlet nozzle cap.
 13. Attach a section of hose or other deflector to protect the street, traffic, and private property from water expelled at high velocity.
 14. Open the hydrant and flush to remove foreign material and until the water is clear. Look for discoloration and debris.
 15. Close the hydrant. Remove the deflector and check the operation of the drain valve by placing the palm of one hand over the outlet nozzle. Drainage should be sufficiently rapid to create noticeable suction.
 16. Using a listening device, check the main valve for leakage.
 17. Remove all outlet-nozzle caps, clean the threads, check the condition of the gaskets, and lubricate the threads with food grade grease. Check the ease of operation of the cap.

18. Check outlet-nozzle-cap chains or cables for free action on each cap. If the chains or cables bind, open the loop around the cap until they move freely. This will keep the chains or cables from kinking when the cap is removed during an emergency.
19. Replace the caps. Tighten them, and then back off slightly so they will not be excessively tight. Leave them tight enough to prevent their removal by hand.
20. Check the lubrication of operating-nut threads. Lubricate per the manufacturer's recommendations.
21. Repair any damage from running water.

CAUTIONS

Hydrants should be opened and closed one at a time to minimize the effect on the distribution system.

Opening a hydrant rapidly can cause a pressure fluctuation. Therefore, hydrants should be opened slowly until fully opened. Closing the hydrants is more critical, and it must be done very slowly. Closing a hydrant rapidly causes a pressure surge, or water hammer, and this could cause a weakened main to fail.

Dry-barrel hydrants must be opened fully because the drain-valve mechanism operates with the main valve. A partially opened hydrant could force water through the drain outlets under pressure, eroding the thrust support from behind the hydrant. After the test, the hydrant barrel should be drained before tightening the outlet-nozzle cap. A tight outlet-nozzle cap could prevent proper drainage and possibly cause ice blockage in either the upper or lower barrels.

Gauge measurements should be taken only when the water is running clear because sediment could damage the instruments.

Never use antifreeze to prevent a hydrant from freezing or to coat the thread of the caps. Under certain conditions antifreeze may be able to enter the water distribution system and cause contamination of the water. Any hydrant found to contain antifreeze must be isolated and steam cleaned to remove all traces of the antifreeze.

Ensure the caps are tightened; a loose cap or damaged nozzle can blow off under pressure.

FIRE FLOW TESTING

PURPOSE

Fire flow tests are conducted on hydrants to determine pressure and flow-producing capabilities at any location within the distribution system. The primary function of fire flow tests is to determine how much water is available for fighting fires, but the tests also serve as a means of determining the general condition of the distribution system. Heavily tuberculated water mains or those with heavy wall deposits can reduce flow-carrying capacities of pipe; this reduced capacity can be detected by means of a flow test. Flow tests can also help detect closed valves in the system. The results of flow tests are used by insurance underwriters as a factor in setting rates for insurance premiums and by designers of fire-sprinkler systems.

It is good practice to conduct flow tests on all parts of the distribution system approximately every 10 years (or whenever needed) to identify the service areas affected by significant changes in the distribution system. NFPA-291 (2010): *'Recommended Practice for Fire Flow Testing and Marking of Hydrants'* recommends that a residual pressure of 20psi be maintained in fire hydrants for them to be effective for firefighting and preventing the contamination of public water supplies by backflow.

For reasonably accurate test results, the pressure drop between static and the residual pressures should be at least 10 psi (70kPa). If the distribution system is strong (as it should be near a supply main) and the pressure drop is less than 10psi, an additional flow hydrant should be added to the test.

There are two types of fire flow tests.

A. Hydrant Capacity Test (One hydrant method):

This test determines the flow rate available from the hydrant in a fire emergency situation. If all hydrants in a system are tested, partially closed valves and other obstructions will become known. This test uses a single hydrant as both the test hydrant and the flow hydrant

Procedure:

- Perform and document hydrant inspection.
- Measure and record the inside diameter (D) of the outlet nozzle from which the flow is to be measured.
- Determine the outlet nozzle-coefficient (c) in accordance with the figure below.

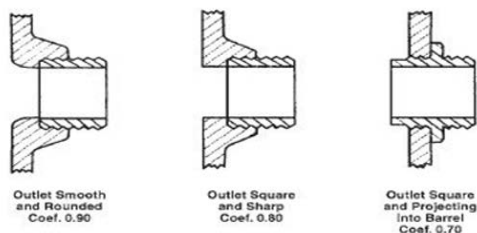

- Attach single or multiple outlet nozzle cap(s) equipped with pressure gauge, air vent and a gate valve.
- Install hydrant flow test kit.
- Close gate valve and tighten all other caps.
- Open the main valve slowly until the air is vented. Close the air vent and open the hydrant main valve fully.
- Read the gauge. This is the static pressure reading.
- Open gate valve slowly until it is fully open.
- Observe the same gauge used to take static pressure reading and record your gauge pressure once the flow rate stabilizes. This is the residual pressure reading.
- Record nozzle pressure/ velocity head (p) from hydrant flow kit or pitot pressure, if the hydrant flow kit is equipped with a Pitot tube. Otherwise, a hand held unit with a pressure gauge and an air release valve can be used in the orientation shown below.

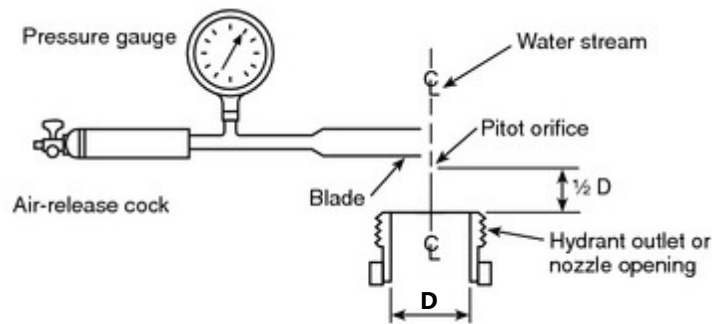

- Slowly close gate valve, then close hydrant slowly to avoid undue surges and damage to the underground system and equipment.
- Remove the testing apparatus and check the operation of the drain valve by placing the palm of one hand over the outlet nozzle. Drainage should be sufficiently rapid to create noticeable suction.
- Clean the threads and lubricate the threads with food grade grease. Check the ease of operation of the cap.
- Check outlet-nozzle-cap chains or cables for free action on each cap.
- Replace the caps. Tighten them, and then back off slightly so they will not be excessively tight. Leave them tight enough to prevent their removal by hand.
- Remove all signage and return hydrant to service.

B. Main Capacity Test (Two hydrant method):

This test determines the water supply available in the water main. Use this test if data from test will be used to design a fire sprinkler system.

Procedure:

- Locate the residual hydrant and do the following:
 - Perform and document hydrant inspection.
 - Install the outlet nozzle cap equipped with the pressure gauge and a gate valve on a hydrant nozzle.
 - Open the main valve slowly until the air is vented. Close the vent and open the main valve fully. No water should be flowing.
 - Read the gauge and this is the static pressure reading.
- Locate the flow hydrant and do the following:
 - Perform and document hydrant inspection.
 - Measure and record the inside diameter (D) of the outlet nozzle from which the flow is to be measured.
 - Determine the outlet nozzle-coefficient (c) in accordance with the figure below:

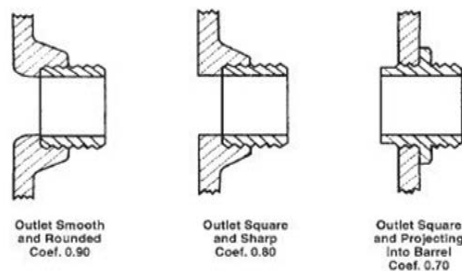

- Install the hydrant flow test kit.
- Install a hose pipe, diffuser, dechlorinator etc. to direct the discharged flow.
- Install the outlet nozzle cap equipped with the pressure gauge on a hydrant nozzle.
- Station one observer at the residual hydrant and one observer at flow hydrant.
- Open the flow hydrant slowly until it is fully open.
- When the pressure at the residual hydrant is stabilized, the observer signals the person stationed at the flow hydrant to take the reading.

- The reading for residual pressure and the nozzle pressure/ velocity head or Pitot tube readings must be taken simultaneously.
- Record the residual reading.
- Record the nozzle pressure/ velocity head (p) from hydrant flow kit or the pitot pressure, if the hydrant flow kit is equipped with Pitot tube. Otherwise, a hand held unit with pressure gauge and air release valve can be used in the orientation shown below.

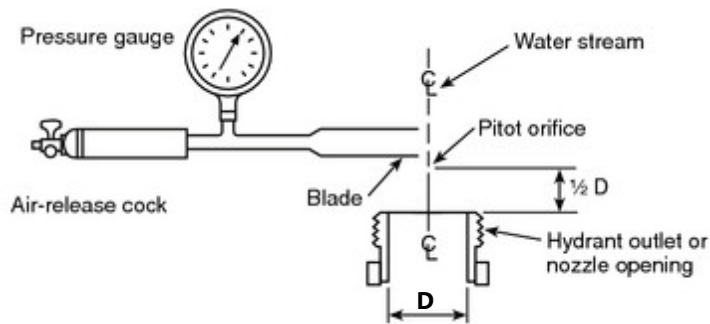

- Close the hydrant slowly to avoid undue surges and damage to the underground infrastructure.
-
- After closing all valves, verify that they are free of leaks and ensure that the hydrant is returned to service condition.

ENVIRONMENT IMPACT

The discharge of a contaminant into the natural environment that causes or is likely to cause an adverse effect or discharge of any material of any kind into or in any waters or on any shore or bank thereof or into or in any place that may impair the quality of the water of any waters is strictly prohibited.

During flushing or hydrant flow testing - the waste water cannot be discharged into a storm sewer or onto land where it may enter a storm sewer or ditch, without being treated to eliminate the chlorine and reduce the toxicity. Even treated water from the existing distribution system cannot be "wasted" without treatment to eliminate the chlorine.

All reasonable steps shall be taken to minimize and ameliorate any adverse effect on the natural environment or impairment of the quality of water of any waters resulting from the operation of the drinking water system.

RECORD KEEPING

An accurate record, filed systematically so it is readily available, should be kept of each test. The Saskatoon Water Division stores data collected from inspections. Hard copies of data are filed in a binder possessed by Saskatoon Water, Future development group.



Sr. No. _____

**DRY BARREL HYDRANT
INSPECTION & FIRE FLOW TEST REPORT**

Hydrant GIS # _____

Location Address _____

Date ____/____/____

Inspection requested by _____

	ASSESSMENT		COMMENTS
	OK/ YES	NO/ Require action	
INSPECTION REPORT			
Hydrants are accessible.			
Visually inspected the hydrant			
Leakages			
Surface cracks			
Paint			
Chains			
Caps			
Stem			
Operating nut condition			
Nozzle threads condition			
Clean and lubricate cap threads			
Functioning of drain valve			
Area restored to its pre-test condition			

	OBSERVED		COMMENTS
	UNIT	VALUE	
FLOW TEST DATA			
Static pressure (residual hydrant)	psi		
Residual pressure (residual hydrant)	psi		
Pitot pressure (flow hydrant)	Psi		
Nozzle size (flowing nozzles only)	inches		
Nozzle coefficient (flow hydrant)	-		
Measured Flow GPM	GPM		
Calculated available flow at 20 psi	GPM		

Name & Signature COS Rep_____
Name & Signature Firm's Rep

FLOW CALCULATIONS

In order for these formulas to make sense, one needs to understand the specific meaning of the following terms.

STATIC PRESSURE

Pressure reading before water flows.

RESIDUAL PRESSURE

Pressure reading while water is flowing (from an outlet other than the flow outlet.)

PITOT PRESSURE

Reading taken by a pitot gauge inserted into the center of the flowing outlet, at a distance away from the lip of the outlet of about half the nozzle's diameter.

COEFFICIENT

Since hydrant nozzles typically don't produce perfect discharge columns, this is a correction factor which is often used to compensate for errant pitot readings. Hydrant manufacturers should be able to provide coefficients for their products. For hydrants where the coefficient is unknown, we use .95 or .9 depending upon how uniform the discharge stream looks when the hydrant is opened. If a flow tube or "stream straightener" is used on the hydrant, the coefficient would be 1.

RESIDUAL BASELINE

A pressure which you determine is the lowest that the hydrant would be pulled down to during actual use. NFPA states that the basis for fire flow calculations will be 20 psi residual, however in low pressure areas they allow calculations based on one-half the static pressure. Ergo, flow from a hydrant that has only a 30 psi static pressure can be calculated on a basis of drawing it down to 15 psi rather than 20.

OBSERVED FLOW

This is a calculation in GPM of the actual flow from one outlet flowing fully opened.

AVAILABLE FLOW

This is the calculated maximum capacity of the hydrant if it is pumped down to the baseline residual pressure (usually 20 psi).

After successfully completing the flow test and recording the information, enter the test data into the following formula to determine the discharge and flow of the hydrant.

RATE OF DISCHARGE ("Q" FORMULA)

The "Q" formula produces a value in GPM (gallon per minute) based on the nozzle diameter and pitot pressure (solving for "Q_F".)

$$Q_F = 29.84(c) (d^2) \sqrt{p}$$

Where Q_F = Observed flow (GPM) c = Coefficient
 d = Outlet diameter (Inches) p = Pitot pressure (psi)

HYDRANT FLOW (HAZEN-WILLIAMS FORMULA)

This formula calculates available flow at desired residual pressure (20 psi) based on the readings taken before and during the flow test (solving for "Q_R")

$$Q_R = Q_F \times \frac{h_r^{0.54}}{h_f^{0.54}}$$

Where;

Q_R = Flow available at desired residual pressure (GPM)
 Q_F = Flow observed during test (GPM)
 h_r = Pressure drop to desired residual pressure (psi)
 h_f = Pressure drop during the test (psi)

Please note that we are calculating to the 0.54 power (a fractional number.)

CONVERSION AID

1 GPM = 0.063902 L/s	1 L/s = 15.850323 GPM
1psi = 6.89476 Kpa	1 Kpa = 0.145038 psi
1 inch = 2.54 cm	1 cm = 0.393701 inch

GLOSSARY

Flow Hydrant — The hydrant that flows water and measures the test flow-rate.

Test Hydrant — Also known as *Residual Hydrant*. In a fire flow test, static and residual pressures are measured at this hydrant. Test results apply to this hydrant.

Hydrant Capacity Test — A single-hydrant fire flow test procedure that evaluates the water supply available from the hydrant. In this test, the residual hydrant is the same as the flow hydrant.

Main Capacity Test — A flow test involving two or more hydrants to evaluate the water supply available at the fire main at the point of the residual hydrant.

Rated Capacity — In fire flow testing, it is the water supply available at a specified residual pressure (usually 20 psi). In fire pump testing, it describes the rated output of the fire pump in terms of a flow-rate such as GPM.

Nozzle Pressure — The pressure measured at a nozzle in a fire flow or fire pump test. It can describe the Pitotless Nozzle, hydrant nozzle or the orifice on the Hose Monster. Nozzle pressure, pitot pressure and velocity pressure are often used interchangeably.

Residual Hydrant — Also known as *Test Hydrant*. In a fire flow test, this hydrant measures static and residual pressures. Test results apply to this hydrant.

Residual Pressure — The pressure residing in the water distribution system when flowing in a fire flow test or any other actual flowing condition.

Static Pressure — Water distribution system pressure at zero test flow.

Test Flow-rate — The flow-rate of water that is discharged in a fire flow or fire pump test.

Bernoulli's Principle — States that a rise (fall) in pressure in a flowing fluid must always be accompanied by a decrease (increase) in the speed of the fluid. Also see Venturi Effect.

Chlorine — An oxidizer used to kill bacteria in drinking water and pools.

Coefficient — Coefficient of discharge or roughness coefficient. A number multiplied with a variable or an unknown quantity.

Conventional Flushing — The practice of opening one or more fire hydrants and allowing water to run until discharge water appears clean. This method does not guarantee removal of sediment or scouring of pipe. Unidirectional flushing is a more deliberate process used for a higher level of cleaning.

Dechlorination — Process of neutralizing the chlorine in discharge water. The standard for dechlorination is AWWA C655-09 Field Dechlorination.

Extrapolate — To infer or estimate by extending or projecting known information. With flow testing, the known information is static pressure and residual pressure at a known test flow-rate. The inference or estimation is flow-rate available at a specified residual pressure psi.

Fire Flow Testing — A test performed to gather information needed to predict fire flow-rates at specific residual pressures. It measures the water supply at a given location.

Flow Device — Equipment used for measuring flow-rate in flow testing, main flushing or pump testing.

Flushing — The procedure of cleaning the inside of a water main by moving large amounts of water through a hydrant or fire pump.

Flushing Velocity — The speed at which water travels through a main while flushing.

Friction Loss — The resulting resistance as water moves along the inside wall of hose, mains, pipe or hose fittings. Friction loss increases exponentially as the flow-rate of water through the hose increases. Friction loss is also influenced by the diameter of the hose, hose length and the inside jacket material.

Gauge Cap — A hydrant cap with a threaded opening for attaching a gauge and drain-cock at the end for relieving air pressure. The gauge cap measures static pressure and residual pressure during a fire flow test.

GPM — Gallons per minute. Describes the rate at which water flows.

Hazen-Williams Formula — Formula which relates the flow of water in a pipe with the physical properties of the pipe and the pressure drop caused by friction. It is used in the design of water pipe systems, such as fire sprinkler systems, water supply networks and irrigation systems. It is named after Allen Hazen and Gardner Stewart Williams.

Hydrant Nozzle — A hydrant nozzle is any of the openings to which the fire department would attach a hose. The exterior thread connection is a specific thread spec, such as NH, NST or Storz.

Main — Refers to a water-distribution main, an underground piping network.

NH — National Hose thread, the most common thread type found on fire hydrants, test headers and standpipes in the United States. (Also called NST — National Standard Thread.)

Nozzle Pressure — Internal pressure measured from the Pitotless Nozzle.

Pitot — Regionally pronounced pee-toe or pit-tot. A pressure-measuring instrument used to measure fluid flow velocity. A hand-held pitot is also used with a pressure gauge to determine flow-rates through hydrant nozzles or other flow devices.

The pitot was invented by Italian-born French engineer Henri Pitot in the early 1700s and modified to its modern form in the mid- 1800s by French scientist Henry Darcy. It is also used in aviation to determine air speed.

Pitot Pressure — The pressure measured at the pitot in a fire flow or fire pump test. Pitot pressure and velocity pressure can sometimes be used interchangeably.

Pitotless Nozzle— A specialty nozzle for flow-rate measurements. No pitot is used. The pressure of the internal nozzle diameter is measured and corresponds to exact water flow-rates. Used in testing fire pumps and for hydrant flow testing.

Predicted Flow — The flow-rate predicted at a given residual pressure, usually 20 psi since most firefighters will bring the system pressure to this threshold when fighting a fire. A fire flow test measures static pressure, residual pressure and test flow-rate. These measurements are used to extrapolate predicted flow.

Residual Pressure — The pressure residing in the water-distribution system when flowing in a fire flow test or any other actual flowing condition.

Static Pressure — Water-distribution system pressure at zero test flow.

Steamer Port — Also known as the pumper port, the 4" or 4½" outlet of a hydrant.

Unidirectional Flushing — The procedure for moving water at high velocity one direction through a single segment of pipe. Closing specified valves in the water distribution system increases the velocity of water. When the pipe diameter and the discharge flow-rate are known, the flushing velocity can be determined.

Valve Exercising — The process of closing and opening a valve until it is determined to be mechanically sound.

Velocity Pressure — The pressure measured at the pitot or nozzle in a fire flow or fire pump test. Pitot pressure and velocity pressure can sometimes be used interchangeably.

Venturi Effect — The reduction in fluid pressure that results when a fluid flows through a constricted section of pipe. The effect holds true for the Pitotless Nozzle. As water flows through the Pitotless Nozzle, water speed increases and pressure decreases.